

INSTRUCTIONS

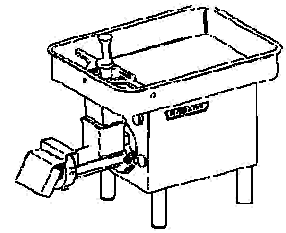

MODEL 4732 CHOPPER

4732 & 4732A CHOPPERS

MODEL

4732 ML-18887 (PAINTED, NON-REMOVABLE PAN)

ML-19282 (SST, NON-REMOVABLE PAN)

4732A ML-19689 (PAINTED, REMOVABLE PAN)

ML-19690 (SST, REMOVABLE PAN)

HOBART

701 S. RIDGE AVENUE
TROY, OHIO 45374-0001
937 332-3000
www.hobartcorp.com

FORM 34747 Rev. A (March 2012)

Installation, Operation and Care of 4732 & 4732A Choppers

SAVE THESE INSTRUCTIONS

GENERAL

The 4732 and 4732A Choppers are equipped with a 3 HP motor that rotates the worm at 151 RPM. The 4732 and 4732A are designed to use a #32 size knife and plate. Knives and plates, available at extra cost, are not included with the chopper.

The stainless steel feed pan on the 4732 is not removable and must be cleaned in place. Model 4732A has a removable stainless steel feed pan and an interlock that requires the feed pan to be in place before the machine can be turned on. On both models, a cast aluminum guard is permanently mounted to the front and sides of the feed pan. Dimensions on the feed pan are 34" long x 21" wide x 5" deep. The motor and switch housing is available in painted steel or stainless steel. The table models use 5 ³/₈" high legs that provide 8" clearance between the table and the lowest point on the adjusting ring. Leg sets of other heights (18" or 21") are available to convert the 4732 or 4732A into a floor model. Sausage stuffers for hog or sheep casings are available accessories.

The chopper can grind 35 to 40 pounds of boneless beef per minute, first cut, through a ¹/₈" plate. The second cut grind rate is 25 to 30 pounds per minute through a ¹/₈" plate. Frozen meat must be tempered to 24° F or higher before grinding and can be in either flake or stick form.

INSTALLATION

UNPACKING

Immediately after unpacking, check for possible shipping damage. If the chopper is found to be damaged, save the packaging material and contact the carrier within 15 days of delivery.

Remove the carton from around the machine. Remove the four bolts holding the machine to the skid. Unpack the feed stomper.

Prior to installation, verify that the electrical service agrees with the specifications on the machine data plate.

Use the spanner wrench to loosen the adjusting ring. Unscrew and remove the adjusting ring using both hands. Remove and discard the retaining washer and rubber pad used at the front of the worm where the knife and plate are to be installed.

The chopper must be thoroughly cleaned and sanitized after installation and before operation. Refer to CLEANING (page 7).

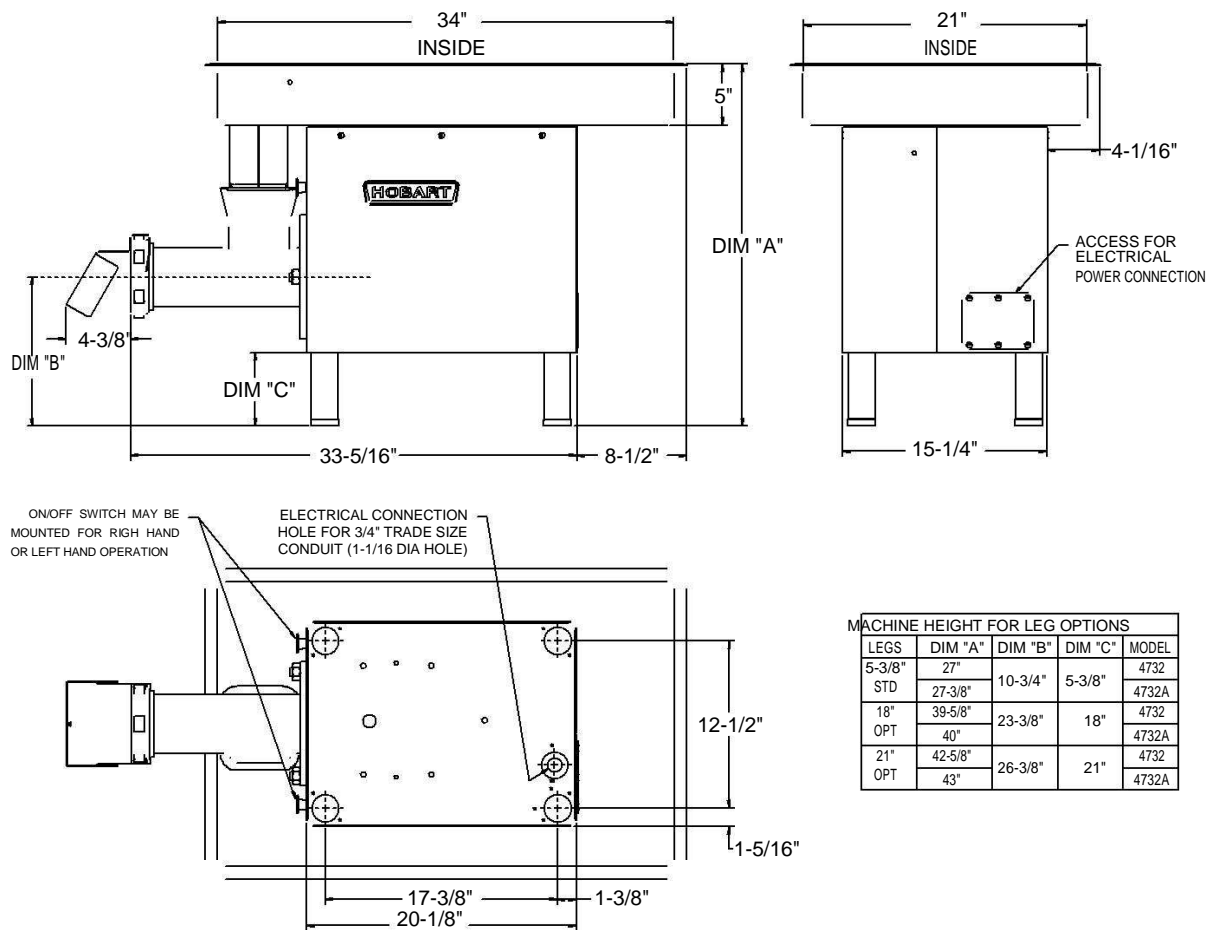

Fig. 1

LEGS (FIGS. 1 & 2)

The four leg assemblies are packed in a separate carton for shipment. The standard legs (5³/₈" high) allow the rim of the feed pan on the table model to be 27" above the table surface. These legs have neoprene feet and require assembly. To assemble 5³/₈" high legs: Slide the Leg Stud through the Leg End Cap and the Leg; then thread the Leg Stud into the base of the machine (Fig. 2). Do not overtighten; the legs need only be hand-tight. Thread the Neoprene Foot into the Leg Stud (Fig. 2).

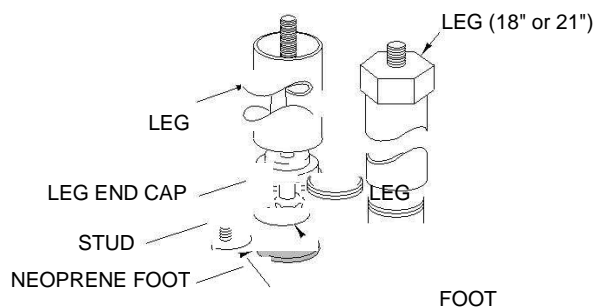

Fig. 2

Floor model choppers are equipped with optional 18" or 21" legs. Each Leg is one piece and threads into the base of the machine at the four corners. These Legs can be adjusted by threading the Feet in or out as necessary (Fig. 2) to level and stabilize the chopper.

PL-56170

ELECTRICAL CONNECTION

⚠ WARNING Electrical and grounding connections must comply with the applicable portions of the national electrical code and/or other local electrical codes.

⚠ WARNING Disconnect electrical power supply and place a tag at the disconnect switch indicating the circuit is being worked on.

A $1\frac{1}{16}$ " diameter hole for $\frac{3}{4}$ " trade size conduit is located in the bottom panel. Remove access panel from the back of the unit. Refer to the machine data plate and the wiring diagram located on the machine for proper sizing of branch circuit. Upon completion, fasten the access panel in place with screws.

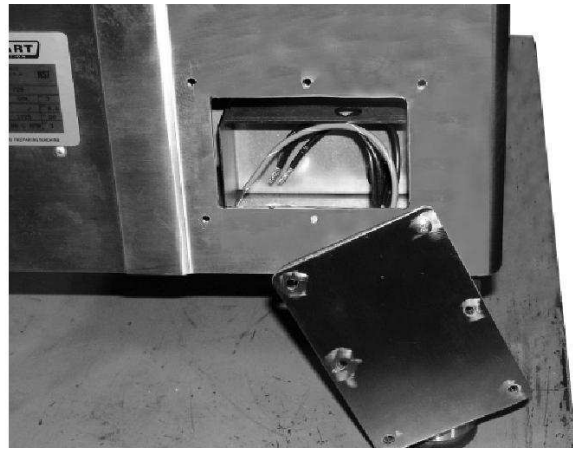
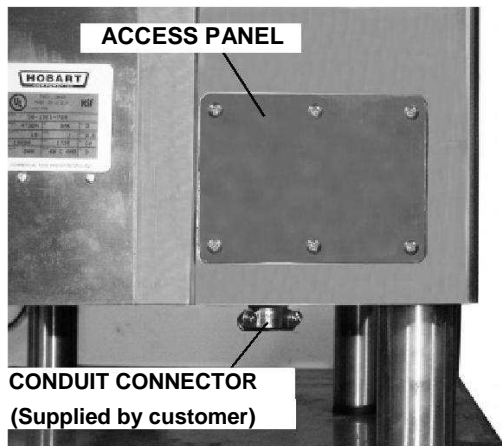

THREE PHASE MACHINES

Three phase machines must be connected so that the attachment drive runs counterclockwise when facing the hub. To check the direction of rotation, turn the chopper on momentarily. If rotation is not correct, DISCONNECT ELECTRICAL POWER SUPPLY and interchange any two of the incoming power supply leads. Reconnect power to the chopper. Turn the chopper on momentarily to verify correct motor rotation.

OPERATION

⚠ WARNING Do not operate without guard over feed opening. Do not put hands into feed opening. Use feed stomper.

After cleaning, assemble chopper Cylinder, Worm, Knife, Plate and Adjusting Ring (and Feed Pan on model 4732A) as discussed in cleaning, page 7, and Fig. 3 or Fig. 4. Place the Deflector over the Adjusting Ring.

- To start the chopper, pull the Start-Stop Switch Knob (Fig. 3 or Fig. 4).
- To stop the chopper, push the Start-Stop Switch Knob.

The fineness of cut depends on the hole size of the chopper's Plate. The Knife and Plate must be kept clean and sharp for a fine cut. The tightness of the Adjusting Ring does not regulate fineness of cut; therefore only moderate tightness is recommended. The Adjusting Ring should be only hand-tight.

Cut the meat into chunks about the size of a fist and place in the Feed Pan. Feed meat under the guard and into the Feed Pan opening. Use the Feed Stomper to dislodge over-sized pieces or to dislodge meat which may become stuck in the Feed Pan opening or the cylinder opening. It is not necessary to force meat through the chopper.

When the product is run through the chopper a second time, more speed is attained by feeding small quantities at a time. Allow the machine to feed at its own rate.

MODEL 4732

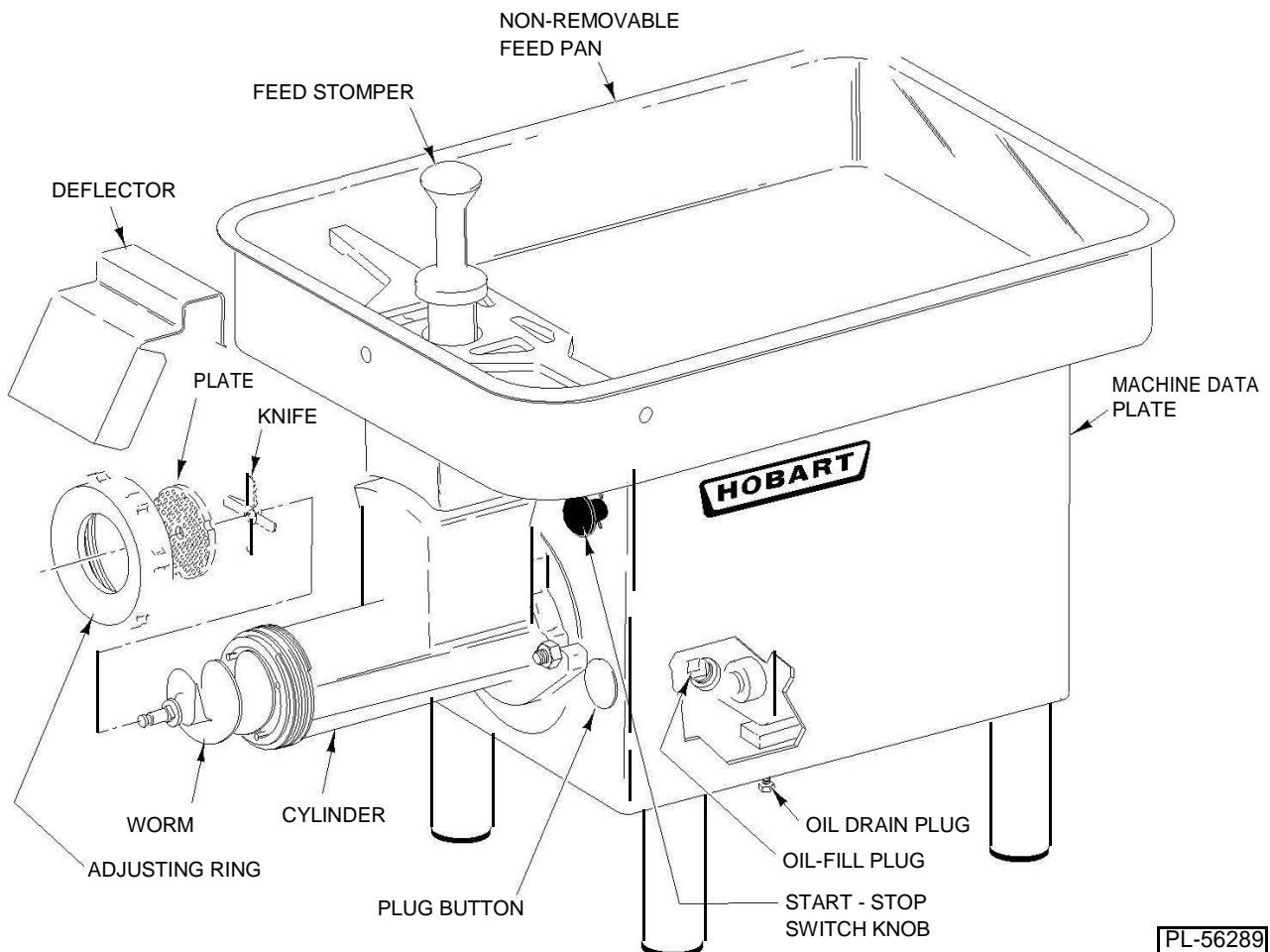

Fig. 3

PL-56289

MODEL 4732A

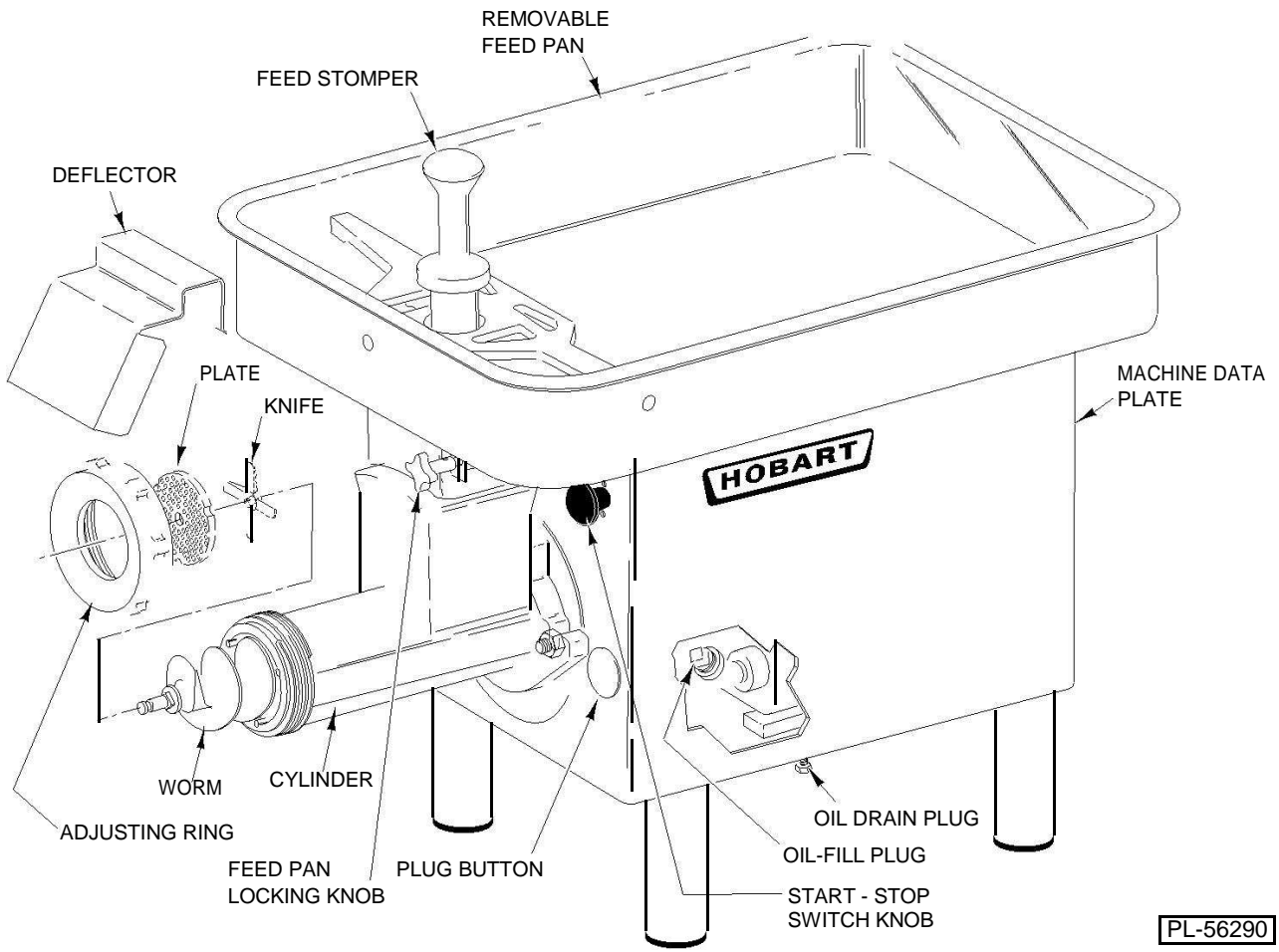

Fig. 4

PL-56290

CLEANING

⚠ WARNING Disconnect electrical power supply and place a tag at the disconnect switch indicating the circuit is being worked on before cleaning, servicing or removing parts.

The chopper should be thoroughly cleaned at the end of each day or any time it is not to be used for an extended period of time.

On model 4732A only, rotate the Feed Pan Lock Knob counterclockwise to unlock the pan (Fig. 5). Slide the Feed Pan toward the chopping attachment until the pan is free of the alignment brackets. Lift off the Feed Pan and take it to a sink for cleaning. On model 4732, the Feed Pan is permanently attached and must be cleaned in place.

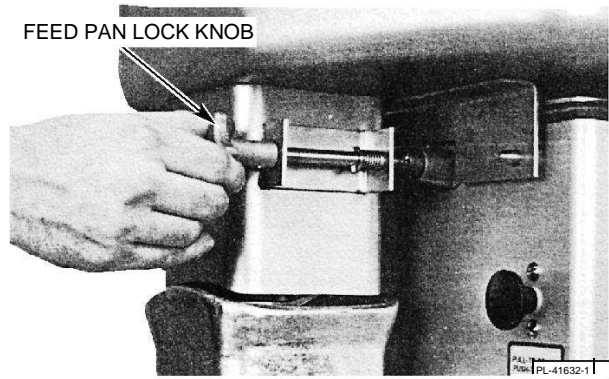

Fig. 5

Pull the Deflector straight up to remove it. Using the spanner wrench, loosen the Adjusting Ring. Unscrew and remove the Adjusting Ring with both hands. Hook the spanner wrench around the Worm stud and pull the Worm end out of the Cylinder. Remove the Knife and Plate and then the Worm. Place the removed parts in a sink for cleaning.

Using the spanner wrench, loosen but do not remove the cylinder nuts. With one hand on bottom of Cylinder for support (it is heavy), turn the Cylinder clockwise and remove to a sink.

Thoroughly clean all removed parts in a sink using hot soapy water and sanitize them. Wipe machine housing with a damp cloth.

Prior to reassembly, apply a light coating of tasteless mineral oil to the inside of the Cylinder, the threads on the Cylinder and the Adjusting Ring, the Worm edges, the Knife and Plate and any other exposed (non-plated) metal surfaces.

To reassemble the machine, first install the Cylinder by rotating it counterclockwise until the ears are under the cylinder nuts. Tighten the cylinder nuts finger-tight.

Slide the Worm into the Cylinder and rotate it to engage the square shank with the attachment drive. With the spanner wrench, tighten the cylinder nuts.

NOTICE Do not over-tighten the cylinder nuts.

Install the Knife (cutting edges out) and the Plate. Screw the Adjusting Ring on hand-tight.

To install the Feed Pan (model 4732A only), slide the alignment bracket (on the bottom of the pan) onto the alignment foot on the chopper housing. Make a visual check to make sure the Feed Pan is squarely on top of the machine. Push the Feed Pan Locking Knob in and rotate it 90° clockwise.

Store the Feed Stomper as shown in Fig. 3 or Fig. 4.

MAINTENANCE

LUBRICATION

During normal operation, gear case oil may require changing due to condensate mixing with the oil. Gear case oil that has mixed with condensate water will have a milky brown color. If this is present, the oil should be replaced.

To change the gear case oil, place a suitable catch pan under the machine and remove the Drain Plug (Fig. 3 or Fig. 4). When old oil is completely drained, replace the Drain Plug. Fill the gear case with 21 fluid ounces of Mobilgear 634 as follows: Remove the Plug Button (Fig. 3 or Fig. 4); then remove the Plastic Oil-Fill Plug (Fig. 6). Pour the proper amount of Mobilgear 634 into the elbow. The gear case is full when the oil is at the bottom thread level of the elbow (Fig. 6). Thread the Plastic Oil-Fill Plug back into the elbow, finger-tight. Press the Plug Button back into the hole of the chopper housing. The chopper requires no other lubrication maintenance.

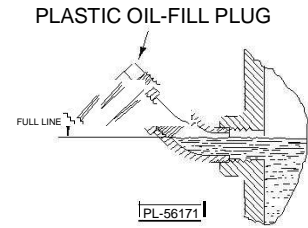

Fig. 6

TROUBLESHOOTING

SYMPTOM	POSSIBLE CAUSE
Chopper will not operate.	Electrical power not connected.
	Circuit Breaker tripped or fuse blown.
	On model 4732A, removable pan is not assembled properly; interlock is not engaged.
	If the above suggestions do not remedy the situation, contact Service.

SERVICE

Contact your local Hobart-authorized Service Office for any repairs or adjustments needed on this equipment.