



CATALOG OF

REPLACEMENT PARTS

MODELS 4732 AND 4732A CHOPPERS

(INCLUDES MOTOR PARTS)



ML-18887	4732 (Painted)
ML-19282	4732 (SST)
ML-19689	4732A (Painted)
ML-19690	4732A (SST)

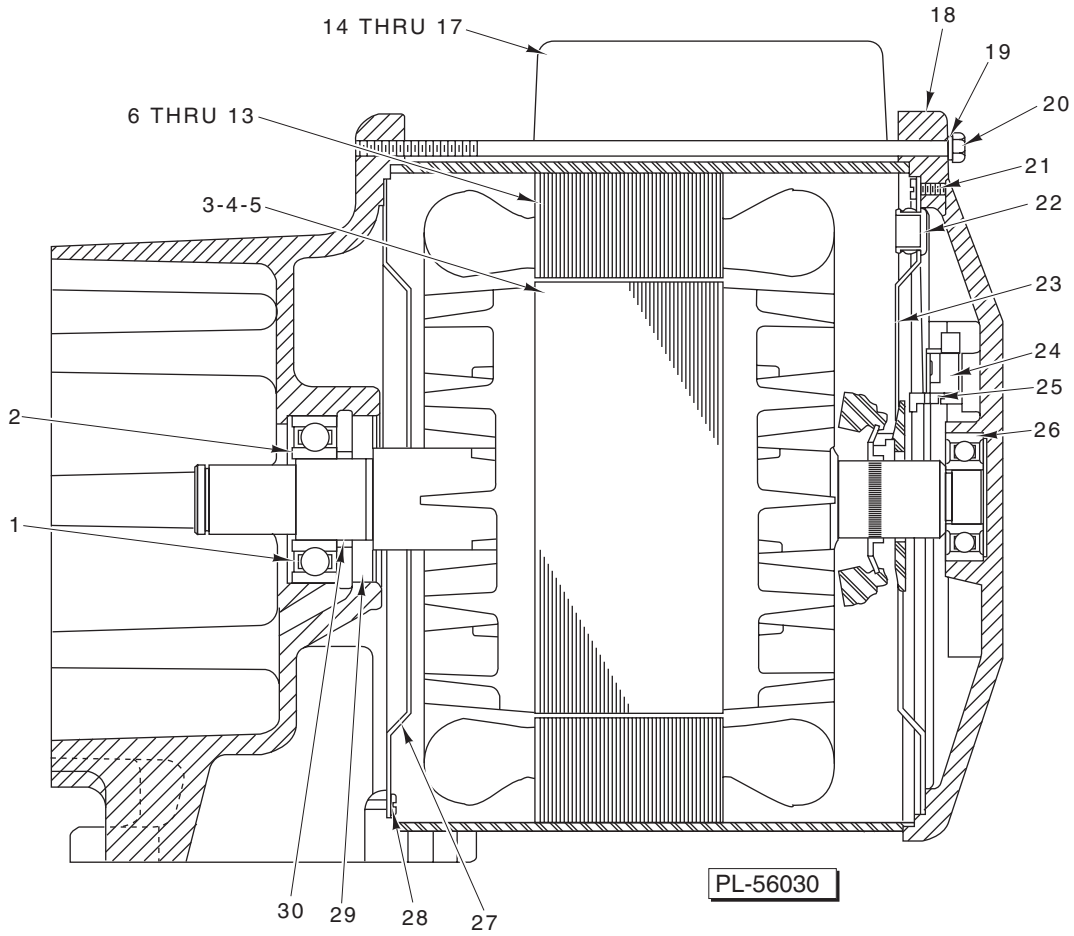

MOTOR UNIT

MOTOR UNIT

ILLUS.	PART NO.	NAME OF PART	AMT.
PL-56030			
1	SL-003-10	Loading Spring	1
2	BB-006-26	Ball Bearing	1
3	00-022275-00232	Rotor Assy. (60 Hz., 1 Ph.)	1
4	00-022275-00233	Rotor Assy. (50 Hz., 1 Ph.)	1
5	00-015747-00264	Rotor Assy. (50/60 Hz. , 3 Ph.)	1
6	00-065477-112-1	Stator Assy. (200 V., 60 Hz., 1 Ph.)	1
7	00-065477-112-2	Stator Assy. (230 V., 60 Hz., 1 Ph.)	1
8	00-065477-112-3	Stator Assy. (220 V., 50 Hz., 1 Ph.)	1
9	00-065478-141-1	Stator Assy. (200 V., 60 Hz., 3 Ph.)	1
10	00-065478-141-2	Stator Assy. (230/460 V., 60 Hz., 3 Ph.)	1
11	00-065478-140-1	Stator Assy. (220/380/415 V., 50 Hz., 3 Ph.)	1
12	FE-016-02	Bushing – Snap (1 Ph.)	3
13	FE-016-02	Bushing – Snap (3 Ph.)	1
14	00-070487-00009	Capacitor (1 Ph.)	2
15	00-089258	Retainer – Capacitor (1 Ph.)	2
16	00-104722	Capacitor Cover & Insulator Assy. (1 Ph.)	2
17	SD-015-27	Self-Tapping Screw 10-24 x 5/16 Pan Hd. Taptite (1 Ph.)	4
18	00-089188-00001	Bracket – Bearing	1
19	WL-003-38	Lockwasher 1/4 Medium	4
20	00-080977-00003	Cap Screw 1/4-28 x 8 ³ / ₈ Hex Hd.	4
21	SC-018-13	Mach. Screw 8-32 x 1/4 Pan Hd. (1 Ph.)	4
22	00-080369	Bushing – Snap (1 Ph.)	1
23	00-089203-00001	Shroud – Fan (1 Ph.)	1
24	00-114514	Starting Switch (Stationary Part) (1 Ph.)	1
25	SC-009-67	Mach. Screw 6-32 x 5/8 Rd. Hd. (1 Ph.)	2
26	BB-005-46	Ball Bearing	1
27	00-089203-00001	Shroud – Fan	1
28	SC-018-13	Mach. Screw 8-32 x 1/4 Pan Hd.	4
29	00-085960	Deflector – Grease	1
30	00-085959	Spacer – Motor Bearing	1

**HOUSING UNIT
(4732)**

ILLUS.	PART NO.	NAME OF PART	AMT.
	PL-56000		
1	00-291592	Plug – Button (2 In.)	1
2	00-086348	Plate – Trim	1
3	SC-022-19	Mach. Screw 10-24 x 1/2 Flat Hd.	2
4	PB-002-08	Plug – Button (25/64 In.)	1
5	SC-010-36	Mach. Screw 10-24 x 5/8 Truss Hd.	2
6	NS-009-22	Nut 10-24 Hex	2
7	00-102825-00001	Gasket – Housing	1
8	NS-013-02	Nut 1/4-20 Hex	1
9	WL-003-38	Lockwasher 1/4 Medium	1
10	00-086165	Screw – Spanner Wrench Support	1
11	00-290481-00004	Housing Assy. (Painted) (60 Hz.)	1
12	00-290481-00005	Housing Assy. (Painted) (50 Hz.)	1
13	00-290481-00006	Housing Assy. (SST) (60 Hz.)	1
14	00-290481-00007	Housing Assy. (SST) (50 Hz.)	1
15	00-069853	Box – Junction	1
16	FE-004-21	Cover – Junction Box (Incls. Gasket)	1
17	NS-009-30	Nut 10-32 Hex	1
18	WL-007-12	Lockwasher #10 External Shakeproof	2
19	SC-060-87	Mach. Screw 10-32 x 3/4 Rd. Hd.	1
20	00-118544-00001	Lug – Solderless	1
21	FE-002-33	Connector – Straight 3/4 Male x 3/4 Flex Conduit	1
22	FE-007-12	Lock Nut 3/4 Conduit	1
23	SC-008-10	Mach. Screw 10-24 x 1/2 Rd. Hd.	8
24	00-116549	Plate – Base	1
25	00-290395-00001	Adjustable Leg Assy. (15 In.) (Incls. Item 28)	4
26	00-290395-00002	Adjustable Leg Assy. (18 In.) (Incls. Item 28)	4
27	00-290395-00003	Adjustable Leg Assy. (21 In.) (Incls. Item 28)	4
28	00-119237	Foot – Adjustable Leg	4
29	00-083681	Foot – Rubber	4
30	00-290061-00001	Stud (5 3/8 In. Lg.)	4
31	00-064814	Cap – End (5 3/8 In. Lg.)	4
32	00-290060-00001	Leg – Standard (5 3/8 In.) (SST)	4
33	ML-034173	Motor (Give Electric Spec.)	1
	00-123771	Kit – Cord	1

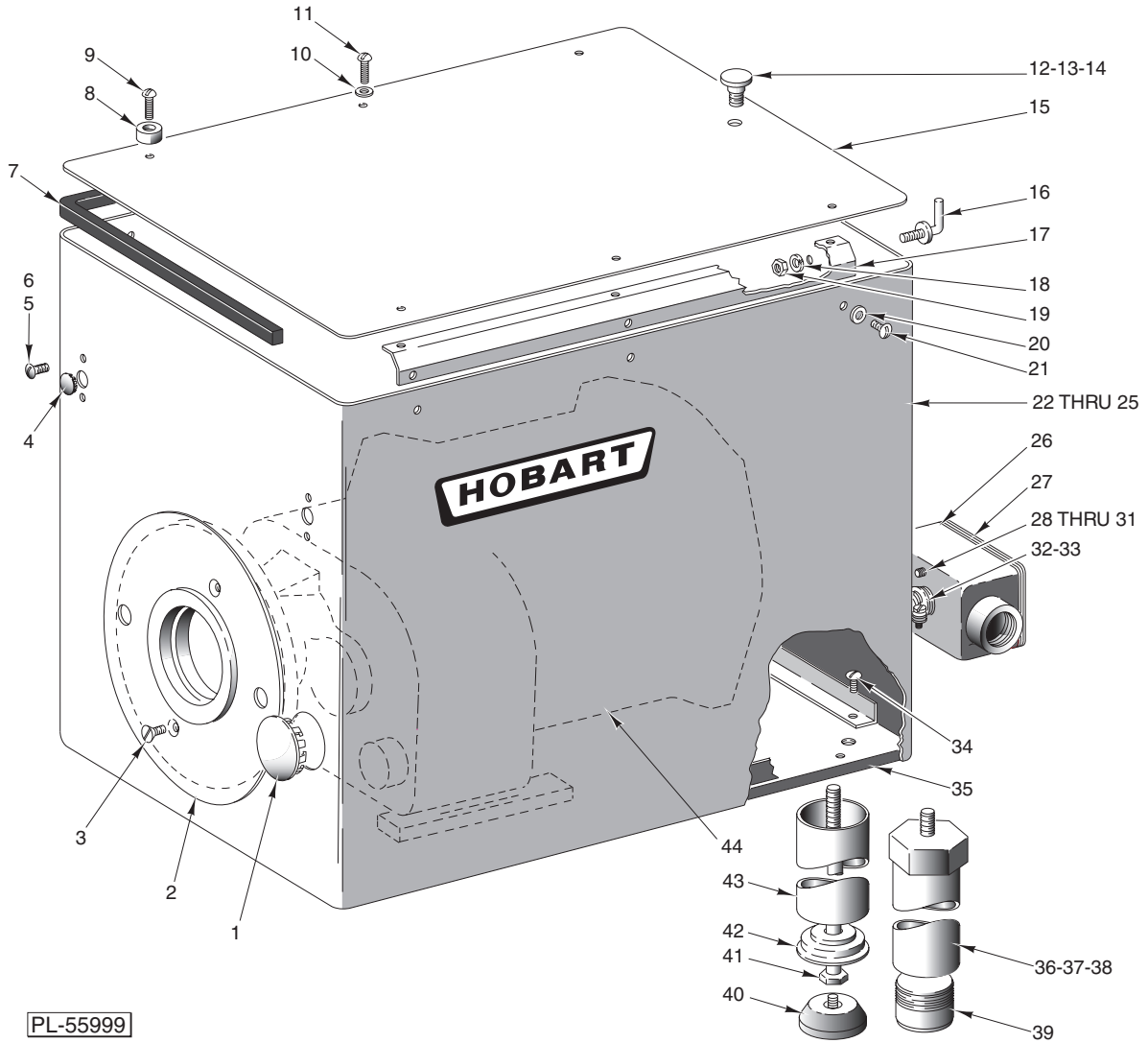

**HOUSING UNIT
(4732A)**

**HOUSING UNIT
(4732A)**

ILLUS. PL-55999	PART NO.	NAME OF PART	AMT.
1	00-291592	Plug – Button (2 In.)	1
2	00-086348	Plate – Trim	1
3	SC-022-19	Mach. Screw 10-24 x 1/2 Flat Hd.	2
4	PB-002-08	Plug – Button (25/64 In.)	1
5	SC-010-36	Mach. Screw 10-24 x 5/8 Truss Hd.	2
6	NS-009-22	Nut 10-24 Hex	2
7	00-102825-00001	Gasket – Housing	1
8	00-019105-00002	Bumper – Pan Rest	4
9	SC-021-25	Mach. Screw 10-24 x 3/4 Rd. Hd.	4
10	WS-019-10	Washer	2
11	SC-010-36	Mach. Screw 10-24 x 5/8 Truss Hd.	2
12	00-124700	Post – Pan Anchor	1
13	WL-004-06	Lockwasher 3/8 Medium	1
14	NS-013-25	Nut 3/8-16 Hex	1
15	00-124702	Cover – Housing	1
16	00-086165	Screw – Spanner Wrench Support	1
17	00-124704	Cover Support Assy.	2
18	WL-003-38	Lockwasher 1/4 Medium	1
19	NS-013-02	Nut 1/4-20 Hex	1
20	WS-019-10	Washer 0.193 x 0.500 x 0.031	6
21	SC-010-36	Mach. Screw 10-24 x 5/8 Truss Hd.	6
22	00-290481-00009	Housing Assy. (Painted) (60 Hz.)	1
23	00-290481-00011	Housing Assy. (Painted) (50 Hz.)	1
24	00-290481-00008	Housing Assy. (SST) (60 Hz.)	1
25	00-290481-00010	Housing Assy. (SST) (50 Hz.)	1
26	00-069853	Box – Junction	1
27	FE-004-21	Cover – Junction Box (Incls. Gasket)	1
28	NS-009-30	Nut 10-32 Hex	1
29	WL-007-12	Lockwasher #10 External Shakeproof	2
30	SC-060-87	Mach. Screw 10-32 x 3/4 Rd. Hd.	1
31	00-118544-00001	Lug – Solderless	1
32	FE-002-33	Connector – Straight 3/4 Male x 3/4 Flex Conduit	1
33	FE-007-12	Lock Nut 3/4 Conduit	1
34	SC-008-10	Mach. Screw 10-24 x 1/2 Rd. Hd.	8
35	00-116549	Plate – Base	1
36	00-290395-00001	Adjustable Leg Assy. (15 In.) (Incls. Item 39)	4
37	00-290395-00002	Adjustable Leg Assy. (18 In.) (Incls. Item 39)	4
38	00-290395-00003	Adjustable Leg Assy. (21 In.) (Incls. Item 39)	4
39	00-119237	Foot – Adjustable Leg	4
40	00-083681	Foot – Rubber	4
41	00-290061-00001	Stud (5 3/8 In. Leg)	4
42	00-064814	Cap – End (5 3/8 In. Leg)	4
43	00-290060-00001	Leg – Standard (5 3/8 In.) (SST)	4
44	ML-34173	Motor (Give Electric Spec.)	1
	00-123771	Kit – Cord	1

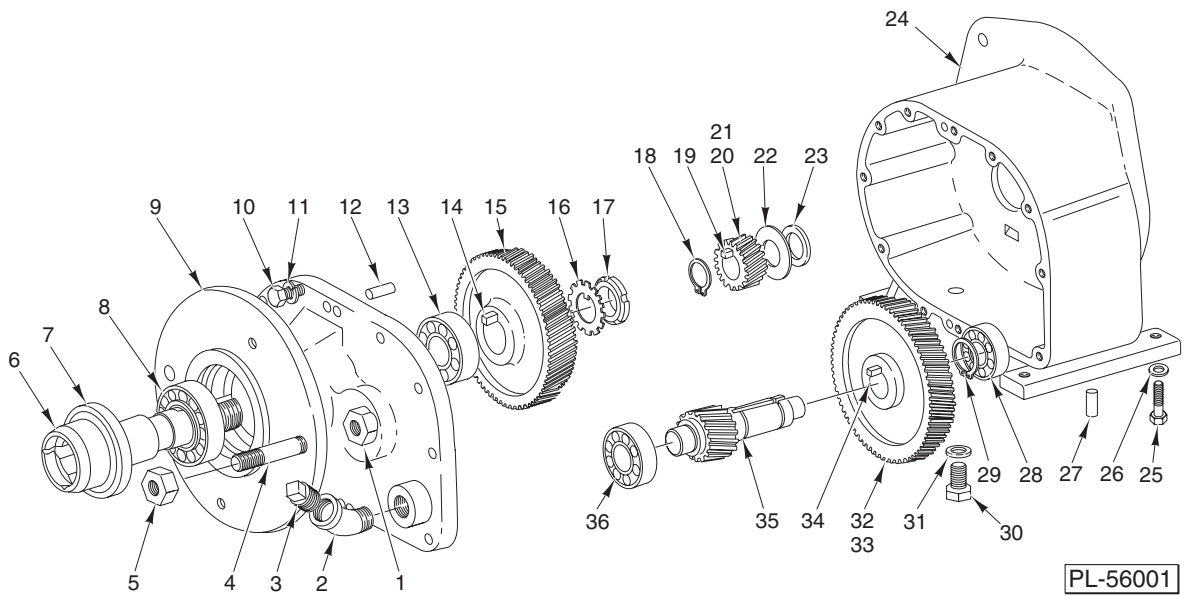

ATTACHMENT HUB AND TRANSMISSION UNIT

ATTACHMENT HUB AND TRANSMISSION UNIT

ILLUS. PL-56001	PART NO.	NAME OF PART	AMT.
1	NS-013-43	Nut $\frac{5}{8}$ -11 Hex	2
2	FP-014-13	Elbow $\frac{3}{4}$ x 45 Deg.	1
3	00-088115-00001	Plug $\frac{3}{4}$ Pipe	1
4	00-072981-00003	Stud – Cylinder	2
5	NS-048-57	Nut $\frac{5}{8}$ -11 Hex	2
6	00-085891	Shaft – Square Drive	1
7	00-085961	Seal – Square Drive Shaft	1
8	BR-002-26	Bearing – Roller	1
9	00-085888	Hub – Attachment	1
10	SC-062-24	Cap Screw $\frac{5}{16}$ -18 x 1 $\frac{1}{2}$ Hex Hd.	12
11	WL-003-45	Lockwasher $\frac{5}{16}$	12
12	00-011800-00239	Dowel	2
13	RB-002-27	Bearing – Roller	1
14	00-109070-00021	Key	1
15	00-089265	Gear – Chopper Drive (60T)	1
16	WL-012-07	Lockwasher	1
17	NS-034-07	Lock Nut	1
18	RR-011-06	Retaining Ring	1
19	00-109070-00002	Key	1
20	00-085896-00001	Gear – Motor Pinion (21T) (60 Hz.)	1
21	00-085896-00002	Gear – Motor Pinion (24T) (50 Hz.)	1
22	00-085957	Flinger – Oil	1
23	00-089804	Spacer – Oil Flinger	1
24	00-116588	Case – Transmission	1
25	SC-118-10	Cap Screw $\frac{3}{8}$ -16 x 1	4
26	WL-004-04	Lockwasher $\frac{3}{8}$	4
27	00-011800-00239	Dowel	2
28	BB-007-14	Bearing – Ball	1
29	RR-007-02	Retaining Ring	1
30	SC-036-93	Cap Screw $\frac{7}{16}$ -20 x $\frac{3}{4}$ Hex Hd.	1
31	WS-021-20	Washer	1
32	00-085892-00001	Gear – Main Drive (68T) (60 Hz.)	1
33	00-085892-00002	Gear – Main Drive (65T) (50 Hz.)	1
34	00-012430-00142	Key	1
35	00-089266	Counter Shaft – Pinion (17T)	1
36	BB-018-33	Bearing – Ball	1

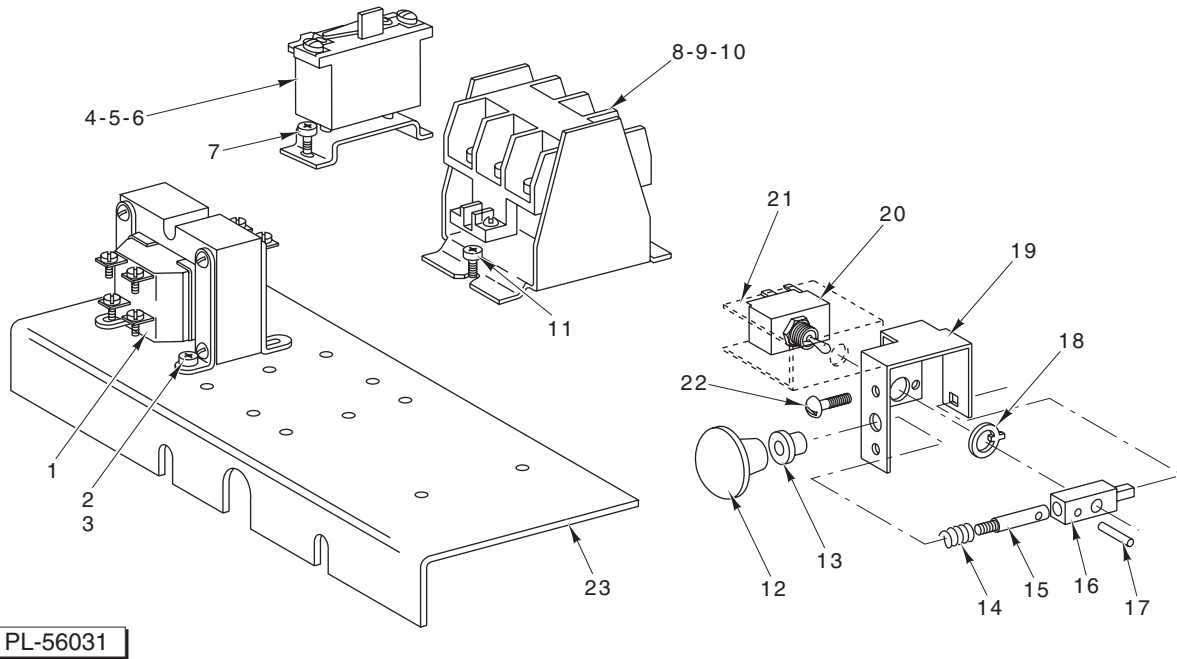

ELECTRICAL UNIT

ELECTRICAL UNIT

ILLUS.	PART NO.	NAME OF PART	AMT.
PL-56031			
1	00-101935	Transformer (200/220/230/380/415/460 V. to 115 V.)	1
2	SD-015-40	Self-Tapping Screw 8-32 x 3/8 Phil. Pan Hd. Taptite	4
3	WL-007-07	Lockwasher #8	4
*4	00-088196-006-1	Relay – Thermal Overload (1 Ph.)	1
*5	00-088196-005-1	Relay – Thermal Overload (3 Ph.)	1
*6	-	Heater Element – Overload Relay (Give Electric Spec., Mach. Model, & Motor Type)	AR
7	SD-015-40	Self-Tapping Screw 8-32 x 3/8 Phil. Pan Hd. Taptite	2
8	00-087713-037-1	Contactory Assy. (200/230 V., 60 Hz., 220 V., 50 Hz.) (2 Pole)	1
9	00-087713-101-1	Contactory Assy. (200/230 V., 60 Hz., 220 V., 50 Hz.) (3 Pole)	1
10	00-087713-101-2	Contactory Assy. (115 V., 50/60 Hz., 3 Pole) (Pilot Circuit)	1
11	SD-015-20	Self-Tapping Screw 10-32 x 3/8 Phil. Pan Hd. Taptite	2
12	00-086163-00001	Knob – Switch Shaft	1
13	00-080538-00001	Bushing	1
14	00-121547	Spring – Compression	1
15	00-124781	Shaft – Switch	1
16	00-124780	Actuator – Switch	1
17	RP-003-06	Rollpin – 1/8 Dia. x 3/4 Lg.	1
18	00-121827	Ring – Locking	1
19	00-123241-00001	Bracket – Switch	1
20	00-120388	Switch & Label Assy.	1
21	00-290058	Insulator – Switch	1
22	SC-010-36	Mach. Screw 10-24 x 5/8 Truss Hd.	2
23	00-271575	Panel – Control	1

*Use with Overload Protection.

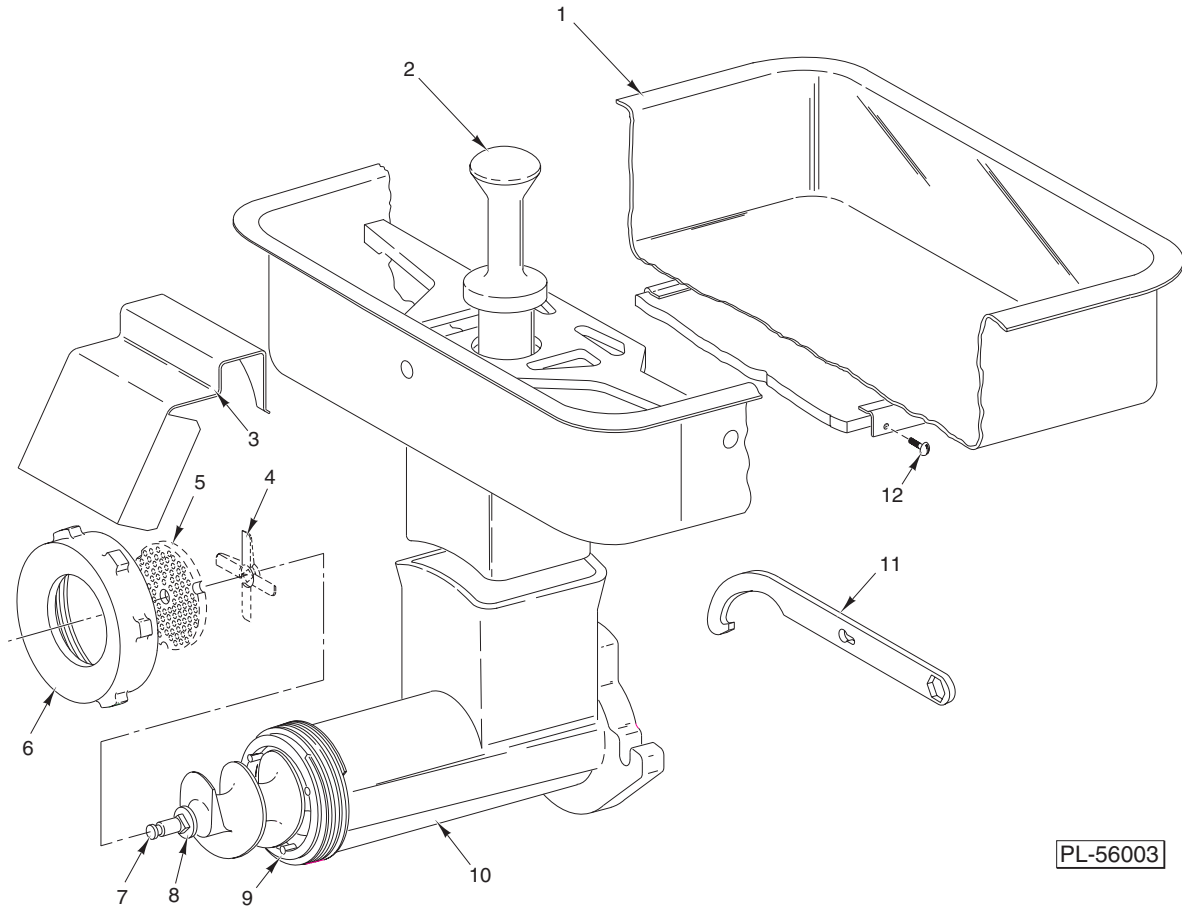

PL-56003

**CHOPPER UNIT
(4732)**

**CHOPPER UNIT
(4732)**

ILLUS.	PART NO.	NAME OF PART	AMT.
PL-56003			
1	00-437416	Feed Pan, Guard, & Insulator Assy. (SST)	1
2	00-089272-00023	Feed Stomper (Plastic)	1
3	00-875250	Deflector – Meat	1
4	-	Knife – Chopper	1
5	-	Chopper Plate	1
6	00-873697	Ring – Adjusting.....	1
7	00-110576	Stud – Plate	1
8	00-111825	Worm Assy. (Incls. Item 7)	1
9	00-105806	Pin – Plate	3
10	00-087309-00001	Chopper Cylinder Assy. (Incls. Item 9)	1
11	00-873570	Wrench – Cylinder	1
12	SC-010-36	Mach. Screw 10-24 x 5/8 Truss Hd.	6
	00-005176	Stuffer – Sausage (Hog Casing) (Not Shown)	1
	00-005194	Stuffer – Sausage (Sheep Casing) (Not Shown)	1

*Sharp, high quality knives and plates should be purchased or rented for this chopper.

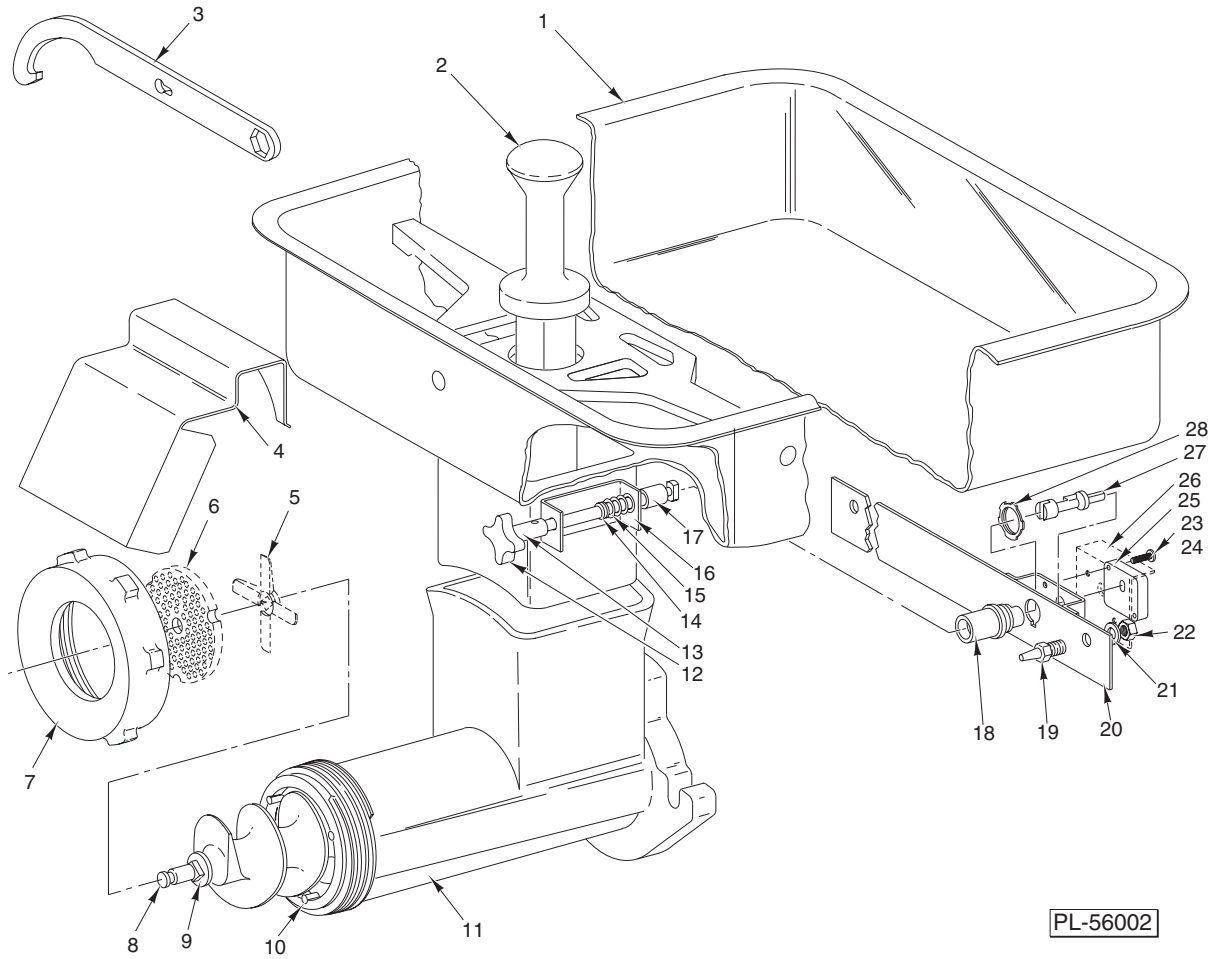

**CHOPPER UNIT
(4732A)**

**CHOPPER UNIT
(4732A)**

ILLUS. PL-56002	PART NO.	NAME OF PART	AMT.
1	00-290116	Feed Pan & Locking Knob Assy. (Incls. Items 12 thru 17)	1
2	00-089272-00024	Feed Stomper (Plastic)	1
3	00-873570	Wrench – Cylinder	1
4	00-875250	Deflector – Meat	1
*5	-	Knife – Chopper	1
*6	-	Chopper Plate	1
7	00-873697	Ring – Adjusting	1
8	00-110576	Stud – Plate	1
9	00-111825	Worm Assy. (Incls. Item 8)	1
10	00-105806	Pin – Plate	3
11	00-087309-00001	Chopper Cylinder Assy. (Incls. Item 10)	1
12	00-124689	Knob – Lock Shaft	1
13	PG-007-41	Grooved Pin 1/8 x 5/8, Type E	1
14	RR-009-10	Retaining Ring	1
15	WS-018-30	Washer	1
16	00-124717	Spring – Compression	1
17	00-124690	Key Shaft Assy.	1
18	00-123988	Housing – Interlock Actuator Shaft	1
19	00-124673	Locator – Feed Pan	2
20	00-124714	Locator Support Assy.	1
21	WL-004-11	Lockwasher 1/2 Medium	2
22	NS-013-33	Nut 1/2-13 Hex Fin.	2
23	SC-081-05	Mach. Screw 4-40 x 3/4 Rd. Hd.	2
24	NS-008-02	Mach. Nut 4-40 Hex	2
25	00-087711-154-1	Switch – Interlock	1
26	00-290059	Insulator – Interlock Switch	1
27	00-124680	Shaft – Interlock Actuator	1
28	FE-006-07	Lock Nut – 1/2-14 (Shaft Housing)	1
	00-005176	Stuffer – Sausage (Hog Casing) (Not Shown)	1
	00-005194	Stuffer – Sausage (Sheep Casing) (Not Shown)	1

*Sharp, high quality knives and plates should be purchased or rented for this chopper.

