



CATALOG OF REPLACEMENT PARTS



4822 CHOPPER

ML-136125

PRIOR ML COVERED IN THIS MANUAL

ML-136102

Table of Contents

3	ELECTRICAL UNIT
5	#22 CHOPPER ATTACHMENT UNIT (NSF)
7	#22 FS CHOPPER ATTACHMENT UNIT (NSF)
9	HOUSING UNIT
11	ATTACHMENT HUB AND MOTOR

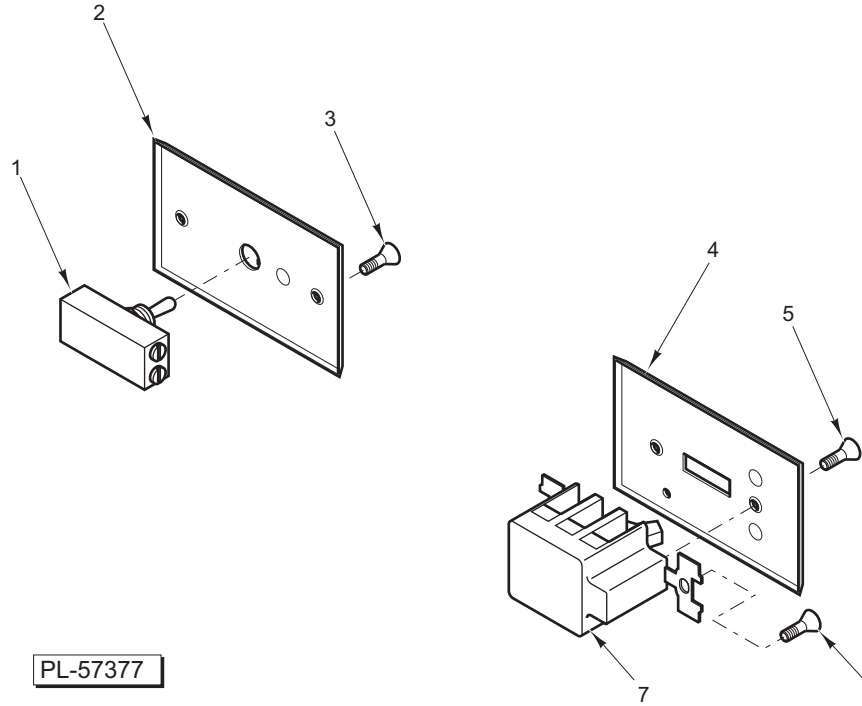

ELECTRICAL UNIT

ILLUS.	PART NO.	NAME OF PART	AMT.
PL-57377			
1	00-944059	Switch Assy. (With 2 Harnesses) (1 Ph.)	1
2	00-291961	Plate – Switch (1 Ph.)	1
3	SC-030-06	Mach. Screw 6-32 x 3/8 Oval Hd.....	2
4	00-124564-00002	Plate – Switch (3 Ph.)	1
5	SC-030-06	Mach. Screw 6-32 x 3/8 Oval Hd.....	2
6	00-074835	Screw – Switch Mounting	2
7	00-087711-138-1	Switch (3 Ph.)	1

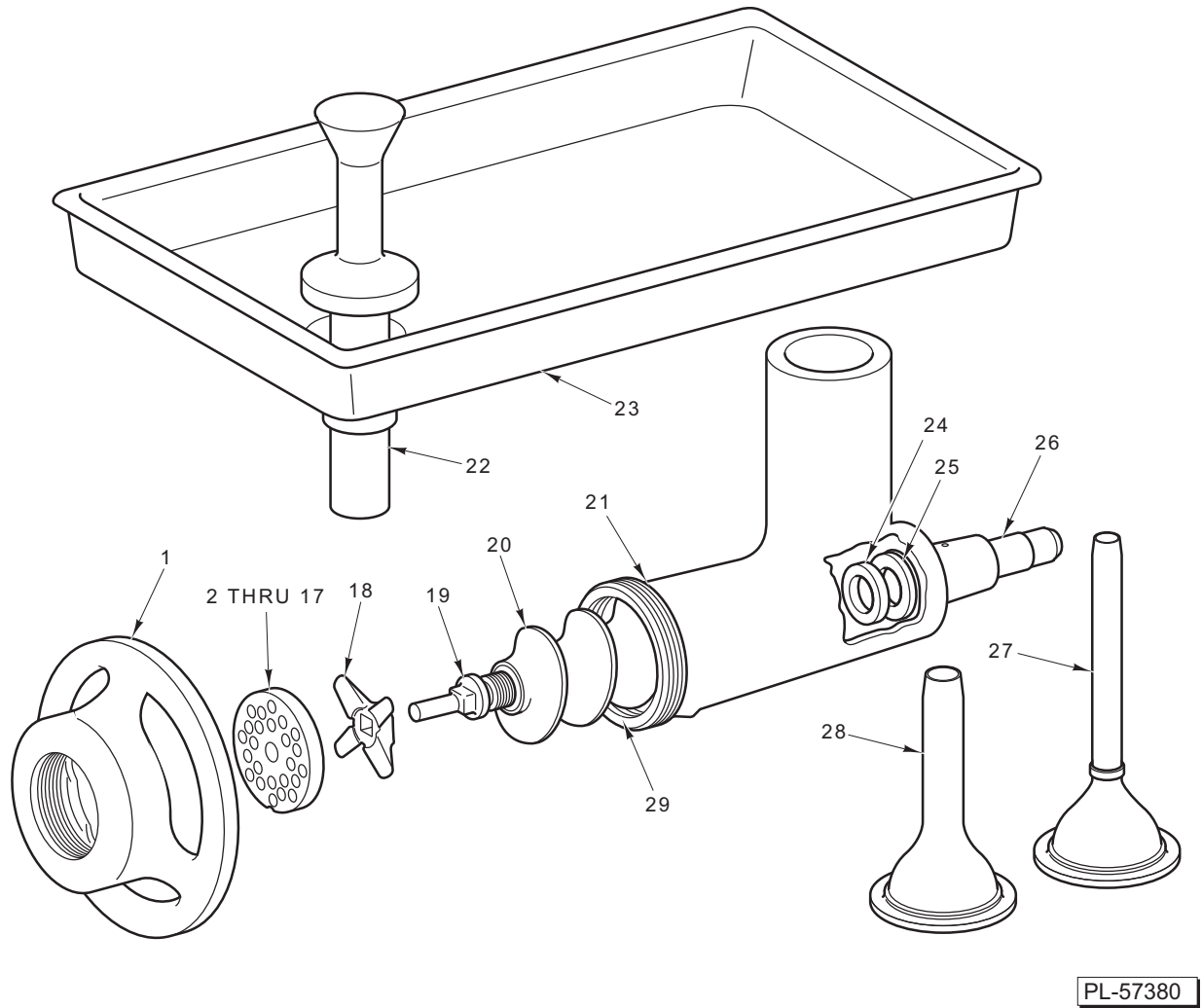

#22 CHOPPER ATTACHMENT UNIT (NSF)

#22 CHOPPER ATTACHMENT UNIT (NSF)

ILLUS.	PART NO.	NAME OF PART	AMT.
PL-57380			
1	00-077643-00002	Ring – Adjusting (Tinned).....	1
2	00-016430-00001	Chopper Plate (1/8 In. Dia. Holes) (Carbon Steel).....	1
3	00-016431-00001	Chopper Plate (3/16 In. Dia. Holes) (Carbon Steel).....	1
4	00-016432-00001	Chopper Plate (1/4 In. Dia. Holes) (Carbon Steel).....	1
5	00-016433-00001	Chopper Plate (3/8 In. Dia. Holes) (Carbon Steel).....	1
6	00-016434-00001	Chopper Plate (1/2 In. Dia. Holes) (Carbon Steel).....	1
7	00-103969-00001	Chopper Plate (5/8 In. Dia. Holes) (Carbon Steel).....	1
8	00-016436-00001	Chopper Plate (3/4 In. Dia. Holes) (Carbon Steel).....	1
9	00-016437-00001	Chopper Plate (15/16 In. Dia. Holes) (Carbon Steel).....	1
10	00-016430-00002	Chopper Plate (1/8 In. Dia. Holes) (Stay Sharp).....	1
11	00-016431-00002	Chopper Plate (3/16 In. Dia. Holes) (Stay Sharp).....	1
12	00-016432-00002	Chopper Plate (1/4 In. Dia. Holes) (Stay Sharp).....	1
13	00-016433-00002	Chopper Plate (3/8 In. Dia. Holes) (Stay Sharp).....	1
14	00-016434-00002	Chopper Plate (1/2 In. Dia. Holes) (Stay Sharp).....	1
15	00-103969-00002	Chopper Plate (5/8 In. Dia. Holes) (Stay Sharp).....	1
16	00-016436-00002	Chopper Plate (3/4 In. Dia. Holes) (Stay Sharp).....	1
17	00-016437-00002	Chopper Plate (15/16 In. Dia. Holes) (Stay Sharp).....	1
18	00-290372	Knife – Chopper (Stay Sharp).....	1
19	00-015880	Stud – Plate.....	1
20	00-015881	Worm Assy. (Incls. Items 19, 24, & 26).....	1
21	00-119760-00001	Chopper Cylinder Assy. (Tinned) (Incls. Items 25 & 29).....	1
22	00-122554	Feed Stomper (Plastic).....	1
23	00-122555	Pan – Feed.....	1
24	00-004221	Washer – Worm Thrust.....	1
25	00-004839-00001	Washer – Cylinder Thrust.....	1
26	00-007201	Stud – Square Drive.....	1
27	00-295184	Stuffer – Sausage (Sheep Casing) (Packaged).....	1
28	00-295182	Stuffer – Sausage (Hog Casing) (Packaged).....	1
29	00-122983	Pin – Plate.....	1

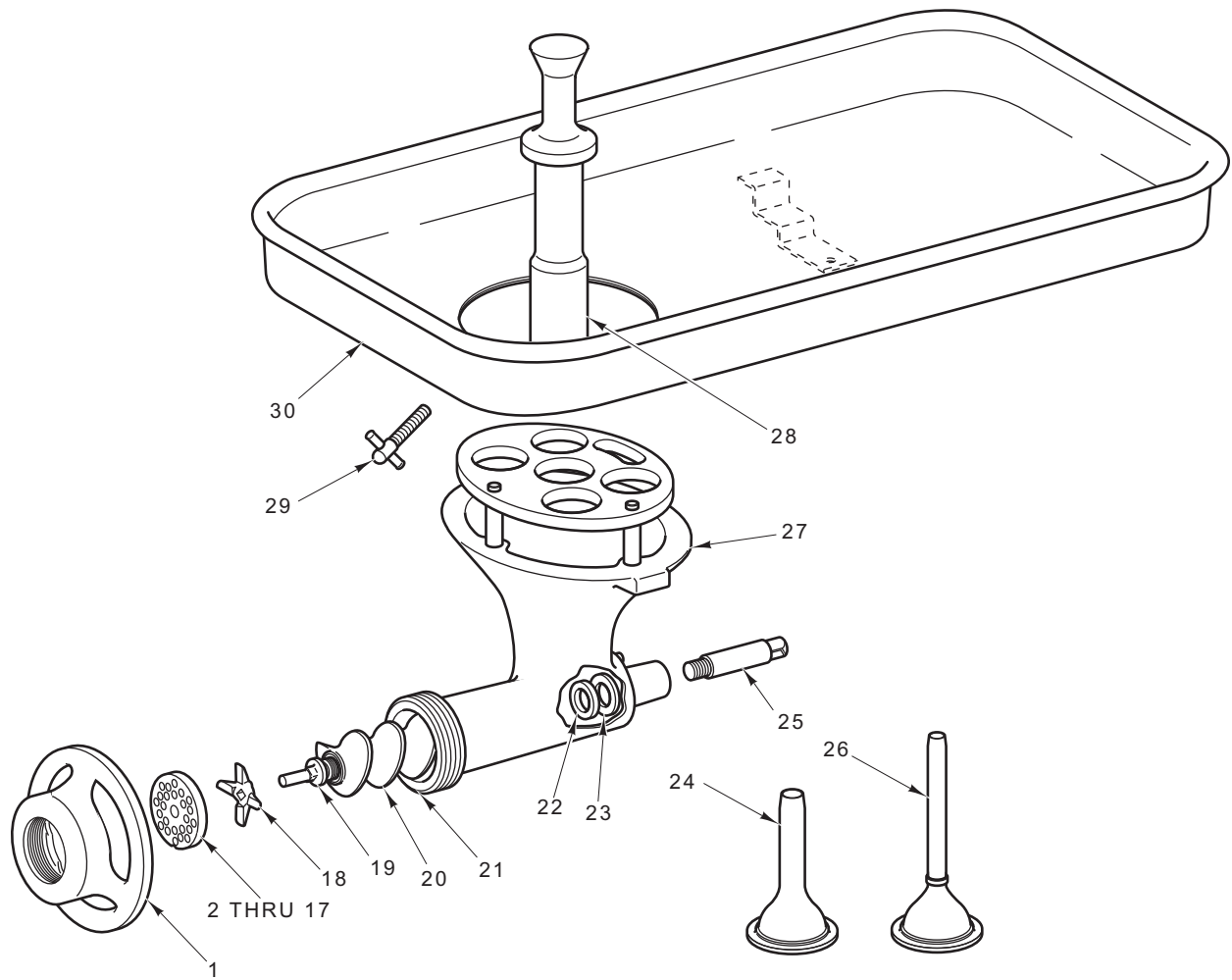

PL-57381

#22 FS CHOPPER ATTACHMENT UNIT (NSF)

#22 FS CHOPPER ATTACHMENT UNIT (NSF)

ILLUS. PL-57381	PART NO.	NAME OF PART	AMT.
1	00-077643-00002	Ring – Adjusting.....	1
2	00-016430-00001	Chopper Plate (1/8 In. Dia. Holes) (Carbon Steel).....	1
3	00-016431-00001	Chopper Plate (3/16 In. Dia. Holes) (Carbon Steel).....	1
4	00-016432-00001	Chopper Plate (1/4 In. Dia. Holes) (Carbon Steel).....	1
5	00-016433-00001	Chopper Plate (3/8 In. Dia. Holes) (Carbon Steel).....	1
6	00-016434-00001	Chopper Plate (1/2 In. Dia. Holes) (Carbon Steel).....	1
7	00-103969-00001	Chopper Plate (5/8 In. Dia. Holes) (Carbon Steel).....	1
8	00-016436-00001	Chopper Plate (3/4 In. Dia. Holes) (Carbon Steel).....	1
9	00-016437-00001	Chopper Plate (15/16 In. Dia. Holes) (Carbon Steel).....	1
10	00-016430-00002	Chopper Plate (1/8 In. Dia. Holes) (Stay Sharp).....	1
11	00-016431-00002	Chopper Plate (3/16 In. Dia. Holes) (Stay Sharp).....	1
12	00-016432-00002	Chopper Plate (1/4 In. Dia. Holes) (Stay Sharp).....	1
13	00-016433-00002	Chopper Plate (3/8 In. Dia. Holes) (Stay Sharp).....	1
14	00-016434-00002	Chopper Plate (1/2 In. Dia. Holes) (Stay Sharp).....	1
15	00-103969-00002	Chopper Plate (5/8 In. Dia. Holes) (Stay Sharp).....	1
16	00-016436-00002	Chopper Plate (3/4 In. Dia. Holes) (Stay Sharp).....	1
17	00-016437-00002	Chopper Plate (15/16 In. Dia. Holes) (Stay Sharp).....	1
18	00-290372	Knife – Chopper (Stay Sharp).....	1
19	00-015880	Stud – Plate.....	1
20	00-068338	Worm Assy. (Incls. Items 19, 22, & 25).....	1
21	00-122983	Pin – Plate.....	1
22	00-004221	Washer – Worm Thrust.....	1
23	00-004839-00001	Washer – Cylinder Thrust.....	1
24	00-295182	Stuffer – Sausage (Hog Casing) (Packaged).....	1
25	00-007201	Stud – Square Drive.....	1
26	00-295184	Stuffer – Sausage (Sheep Casing) (Packaged).....	1
27	00-085386	Chopper Cylinder & Guard Assy. (Guard 1 3/8 High) (Incls. Items 21 & 23).....	1
28	00-089272-00008	Feed Stomper (Plastic).....	1
29	00-022306	Clamp Screw Assy.....	1
30	00-437381	Feed Pan Assy. (SST) (Incls. Item 29).....	1

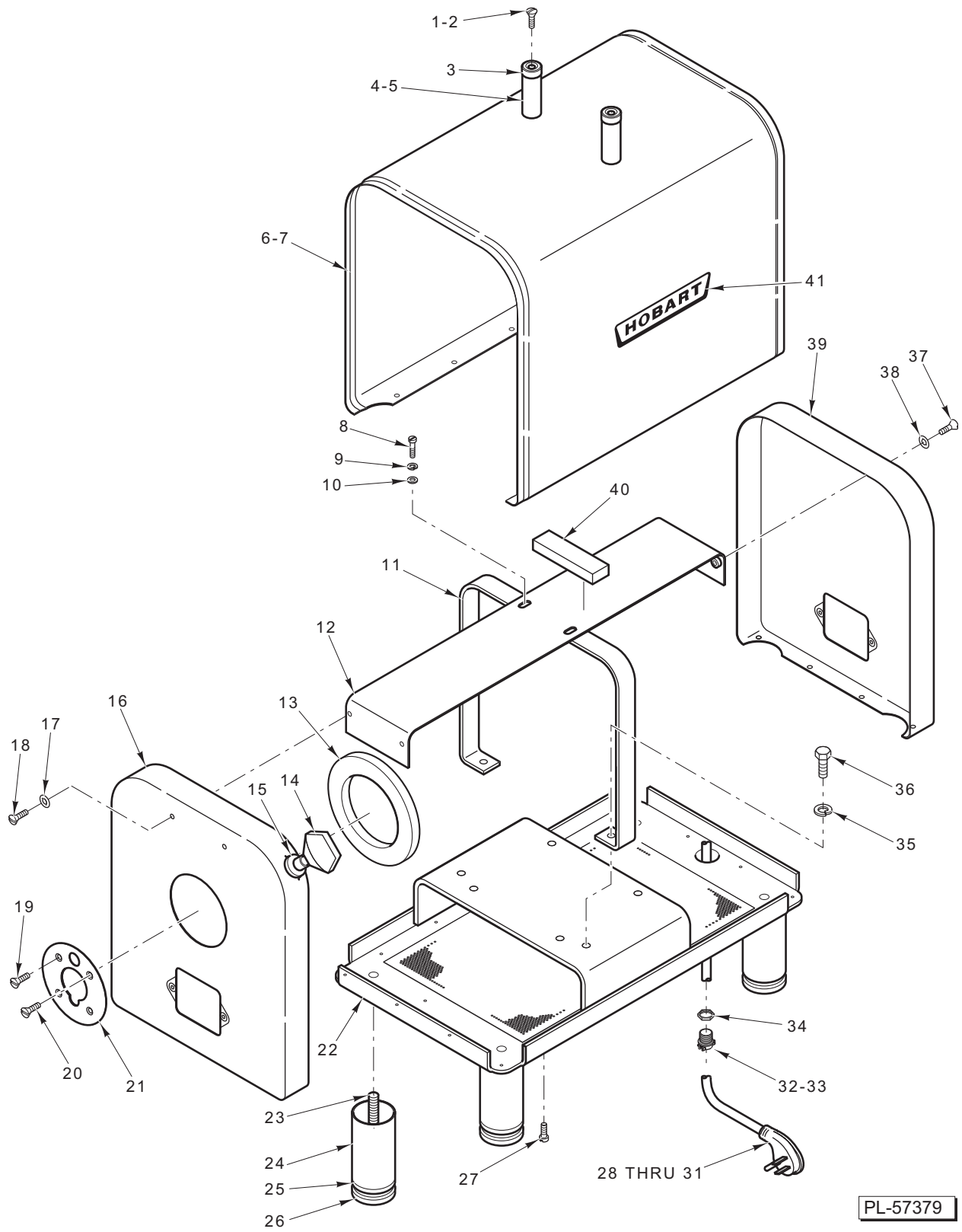

HOUSING UNIT

HOUSING UNIT

ILLUS. PL-57379	PART NO.	NAME OF PART	AMT.
1	SC-060-10	Mach. Screw 8-32 x 3 Rd. Hd.	2
2	SC-009-96	Mach. Screw 8-32 x 1 ¹ / ₄ Rd. Hd. (Use With FS Chopper Attachment)	2
3	00-019105-00001	Bumper	2
4	00-119911	Spacer – Pan Rest.....	2
5	00-065999-00002	Spacer – Pan Rest (Use With FS Chopper Attachment)	2
6	00-290481-00018	Housing Assy. (60 Hz.).....	1
7	00-290481-00019	Housing Assy. (50 Hz.).....	1
8	SC-010-16	Mach. Screw 10-24 x 1/2 Truss Hd.....	2
9	WL-007-12	Lockwasher #10 External Shakeproof	2
10	WS-023-07	Washer.....	2
11	00-875720	Support – Frame & Housing	1
12	00-875722-00001	Bracket – Locating	1
13	00-064818	Gasket – Attachment Hub.....	1
14	00-108197-00004	Thumb Screw Assy.	1
15	00-064824	Grommet (Thumb Screw)	1
16	00-064804-00008	Panel – Front Housing	1
17	WC-004-10	Washer – Countersunk	2
18	SC-015-36	Mach. Screw 10-24 x 5/8 Oval Hd.....	2
19	SC-022-17	Mach. Screw 10-24 x 5/8 Flat Hd.	3
20	SC-022-16	Mach. Screw 10-24 x 5/16 Flat Hd.	1
21	00-914106	Washer – Trim (Attachment Hub)	1
22	00-875551	Frame Weldment	1
23	00-290061-00002	Stud – Leg	4
24	00-290060-00002	Leg.....	4
25	00-064814	Cap – Leg End.....	4
26	00-083681	Foot – Rubber.....	4
27	SC-025-07	Mach. Screw 10-24 x 5/16 Bndg. Hd.....	18
28	00-117542-00098	Cord & Plug Assy. (120 V., 60 Hz., 1 Ph.).....	1
29	00-117542-00097	Cord & Plug Assy. (240 V., 60 Hz., 1 Ph.).....	1
30	00-117612-00020	Cord & Plug Assy. (208-240 V., 60 Hz., 3 Ph.).....	1
31	00-117612-00021	Cord & Plug Assy. (480 V., 60 Hz., 3 Ph.).....	1
32	FE-008-20	Strain Relief (1 Ph.)	1
33	FE-015-38	Strain Relief (3 Ph.)	1
34	FE-007-12	Lock Nut 3/4 Electrical.....	1
35	WL-003-47	Lockwasher 5/16 Medium	2
36	SC-036-40	Cap Screw 5/16-18 x 1 ¹ / ₄ Hex Hd.....	2
37	SC-015-36	Mach. Screw 10-24 x 5/8 Oval Hd.....	2
38	WC-004-10	Washer – Countersunk	2
39	00-064805-00008	Panel – Rear Housing.....	1
40	00-064810	Strip – Compression	2
41	00-118365	Logo – Hobart.....	1

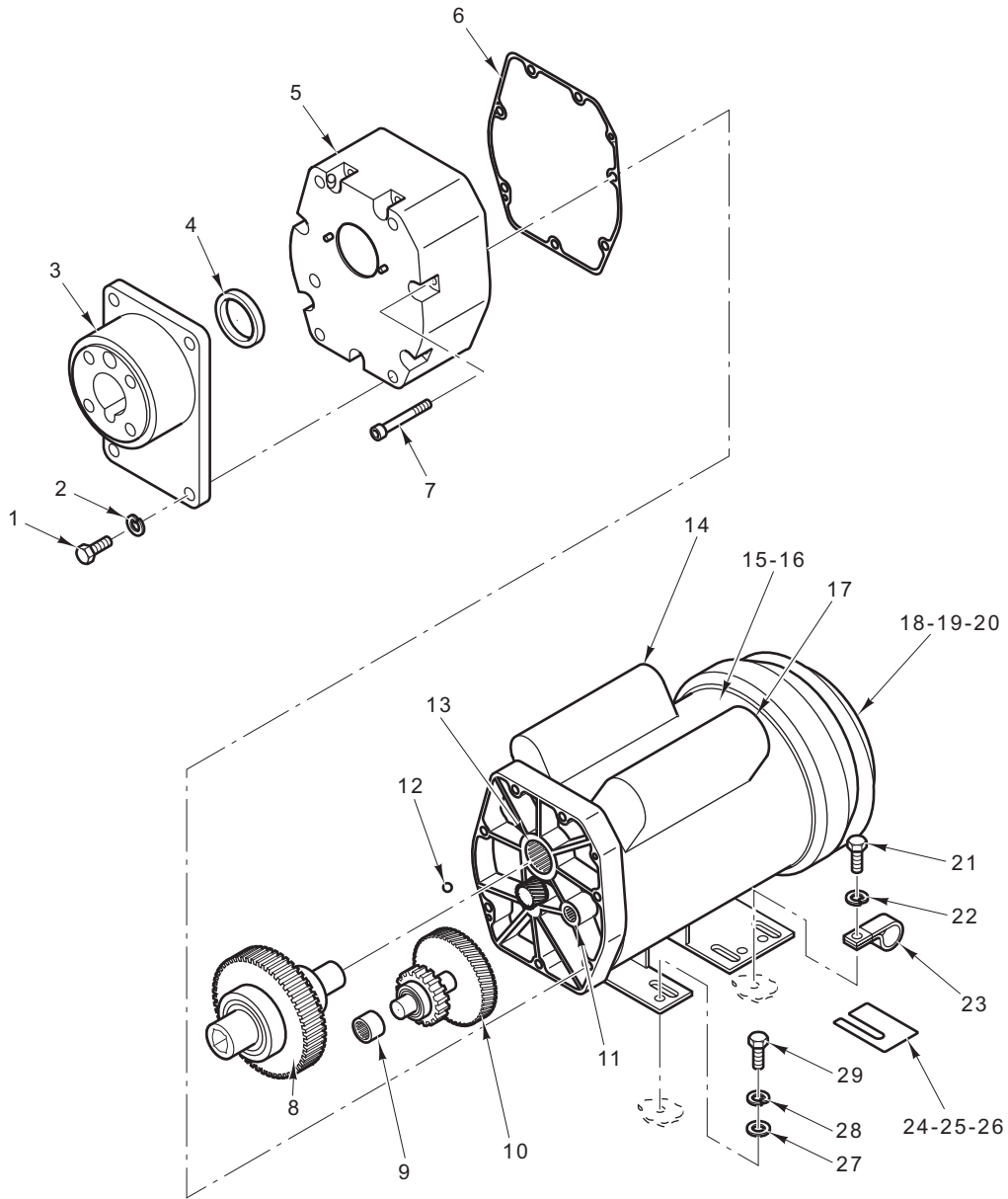

PL-57378

ATTACHMENT HUB AND MOTOR

ATTACHMENT HUB AND MOTOR

ILLUS.	PART NO.	NAME OF PART	AMT.
PL-57378			
1	SC-037-86	Cap Screw $\frac{7}{16}$ -14 x 1 Hex Hd.....	4
2	WL-004-10	Lockwasher $\frac{7}{16}$ Helical	4
3	00-914157	Hub – Adapter.....	1
4	00-914156	Seal.....	2
5	00-914125	Housing Assy.	1
6	00-914131	Gasket	1
7	SC-129-15	Cap Screw $\frac{1}{4}$ -20 x $2\frac{3}{4}$ Hex Socket Hd.....	7
8	00-914127	Gear Assy. (Low Speed)	1
9	00-914252	Bearing – Needle	1
10	00-914126	Gear Assy. (High Speed)	1
11	00-914253	Bearing – Needle	1
12	00-914202	Ball – Steel.....	3
13	00-914254	Bearing – Needle	1
14	00-914278	Capacitor – Start (1 Ph.).....	1
15	00-914275	Motor (1 Ph.).....	1
16	00-914201	Motor (3 Ph.).....	1
17	00-914279	Capacitor – Run (1 Ph.).....	1
18	00-914251	Washer – Wavy.....	1
19	00-914247	Kit – Fan	1
20	00-914249	Switch – Motor Start (1 Ph.).....	1
21	SC-027-28	Mach. Screw 8-32 x $\frac{1}{4}$ Rd. Hd.....	1
22	WL-011-01	Lockwasher.....	2
23	00-078752-00004	Clamp – Wire	1
24	00-914128-00001	Shim – Motor (0.005 Thk.)	AR
25	00-914128-00002	Shim – Motor (0.010 Thk.)	AR
26	00-914128-00003	Shim – Motor (0.020 Thk.)	AR
27	WS-029-86	Washer.....	4
28	WL-003-47	Lockwasher $\frac{5}{16}$ Medium	4
29	SC-036-40	Cap Screw $\frac{5}{16}$ -18 x $1\frac{1}{4}$ Hex Hd.....	4

