

# FICHA TÉCNICA

## LAVAOZA E400-3



**ecomax**



MODELO E400-3

CÓDIGO DE PRODUCCIÓN 917639

INTERFAZ

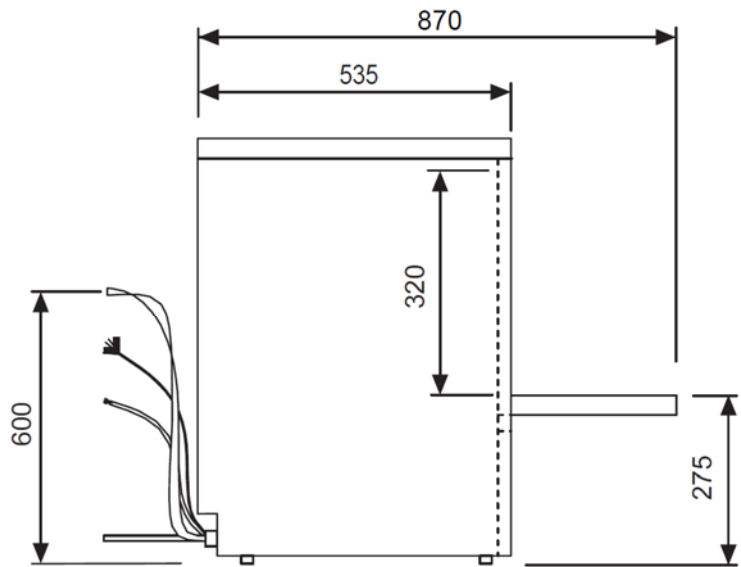
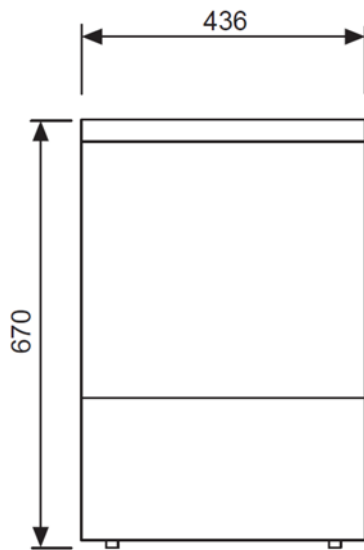

	*Overall Dimension (Width-Depth-Height *open *Packaging Dimension (WxDxH) *Gross weight *Net weight *Volumen	mm mm kg kg mc	436 x 535 (870*) x 670 610x520x840 34 31 0,27
	*Rack size *Max door /hood opening *Max glasses/plate Height *General construction *Door/hood Construction	mm mm mm	390x390 320 300x300 single skin double skin
	*Tank construction *Tank volume *Tank heating element *Tank surface strainers	liter W	welded 8 550 composite
	*Wash pump type *Wash pump power *Wash temperature	W °C	double flow 200 60
	*Boiler type *Boiler volume *Back - flow system *Boiler heating element	liter W	pressurized 2,6 Valve 2400
	*Rinse booster pump *Rinse booster pump power *Rinse temperature *Rinse water consumption *Optimal external water pressure	W °C Liter /rack bar	NO - 65 2 2-4
	*Drain system *Drain filter *Drain pump		overflow double filtering optional
	*Rinse aid dispenser *Detergent dispenser	peristaltic peristaltic	YES optional
	Wash cycle	sec	90 - 120 - 150
	*Electric Power *Electric Connection *Fuse	W V - ph - Hz A	3150 220V 1N 50Hz 16
	*Water softner		NO
	*Plates racks *Flat Rack *Support for saucers *Cutterly Rack *Electric cable *Drain hose *Fill hose	n°- n°2 n°- n°1 n°1 n°1 n°1	NO 780133 NO 780139 YES YES YES

**TW** FOOD  
EQUIPMENT  
GROUP  
**L A T I N O A M É R I C A**

DEDICADOS AL AVANCE DE LAS TECNOLOGÍAS  
Y AL DISEÑO DE EQUIPO PARA LA MEJORA  
CONTINUA DE LA INDUSTRIA CULINARIA.

SERVICIO OTORGADO A TRAVÉS DE HOBART MÉXICO.

**CORPORATIVO LATINOAMÉRICA**

VIVEROS DE LA COLINA #238, VIVEROS DE LA LOMA,  
TLALNEPANTLA, EDO. DE MEX. C.P. 54080  
T. (55).67.200.830

**ECOMAXMEXICO.COM**

