



Project \_\_\_\_\_  
 AIA # \_\_\_\_\_ SIS # \_\_\_\_\_  
 Item # \_\_\_\_\_ Quantity \_\_\_\_\_ C.S.I. Section 114000



## CL66-BAS GAS

### High Temperature Rack Conveyor Dishwashing Machine

CL SERIES – CL66-BAS GAS



#### STANDARD FEATURES

- + 90 gallons per hour pumped final rinse
- + 202 racks per hour
- + 22" power scrapper
- + Complete Delime™ with Delime Notification, Auto Dispensing and Booster Guard™
- + Internal stainless steel pressure-less 18 kW booster heater (70°F rise)
  - Single point electrical connection standard
- + Capless, anti-clogging wash arms
- + Self-aligning wash manifolds
- + Large double door opening for ease of cleaning
- + 19.5" chamber height opening (accepts sheet pans)
- + Doors are insulated & hinged with door interlock switches
- + User-friendly touchscreen controls with diagnostics & troubleshooting
- + WiFi connectivity
- + SmartConnect app with machine status, temperature logs, error code reporting, and cost, consumption and usage analysis
- + Energy saver mode (programmable auto-shut down)
- + NSF rated configurable pot and pan cycle
- + Stainless steel self-draining pump and impeller
- + Sloping scrap screens and deep scrap baskets
- + Rapid return conveyor drive mechanism
- + Service diagnostics
- + Door actuated drain closure
- + Vent fan control
- + Convertible hot water or low temperature final rinse
- + Booster heater control

#### SPECIFIER STATEMENT

Specified dishwasher will be Hobart CL66 Base gas tank heat model. Features include Complete Delime™ with Delime Notification, Auto Dispensing and Booster Guard™, capless anti-clogging wash arms, 202 racks per hour, 90 gallons per hour pumped final rinse, insulated ergonomic cabinet style doors, touchscreen controls with WiFi connectivity, and NSF approved (pending) pot and pan cycle mode. The 19.5" standard chamber height will accommodate up to (6) standard sheet pans at a time on an open-end sheet pan rack.

#### OPTIONS & ACCESSORIES (Available at extra cost)

- Standard, short and extended stainless steel vent hoods
- Non-booster
- Direct drive unloader – adds 38" length; Reference spec F48944 for more details
- Side loader – SL23 adds 23" length, SL30 adds 30" length; Reference specs F40926 and F40927 for more details
- Blower-dryer – adds 33¼" to length; Reference spec F48945 (electric blower-dryer) and F48950 (steam blower-dryer) for more details (ships separate from dishmachine, contact Hobart Service for installation)
- Drain water tempering kit
- Flanged feet kit (requires three kits)
- Table limit switch with 20' cable
- Correctional package (factory installed, contact Hobart for details)
- Water hammer arrester
- Factory-mounted circuit breakers (contact Hobart for details)

Approved by \_\_\_\_\_ Date \_\_\_\_\_ Approved by \_\_\_\_\_ Date \_\_\_\_\_



# CL66-BAS GAS

## High Temperature Rack Conveyor Dishwashing Machine

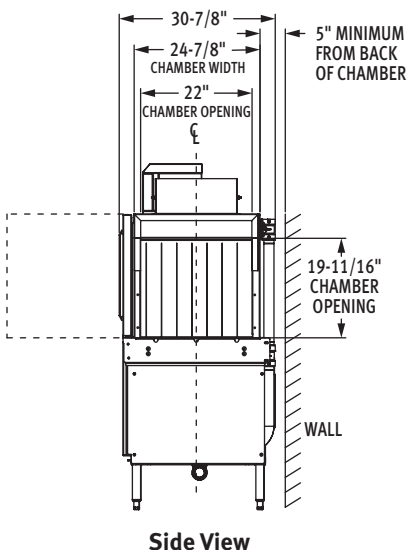
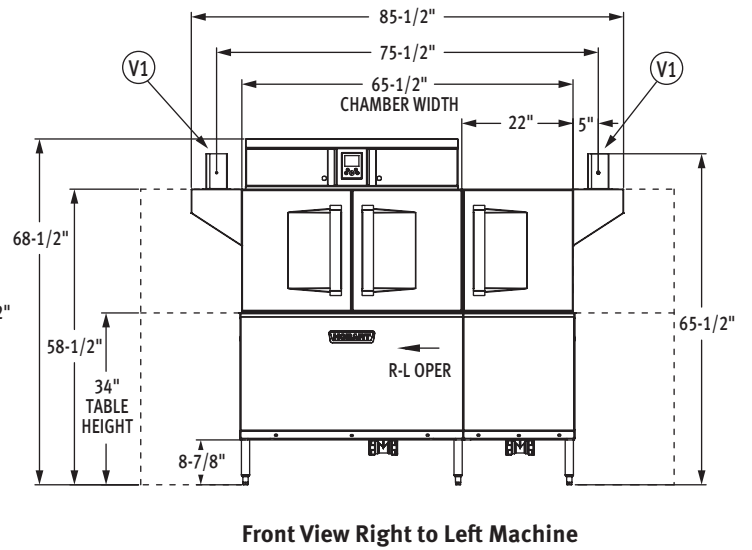
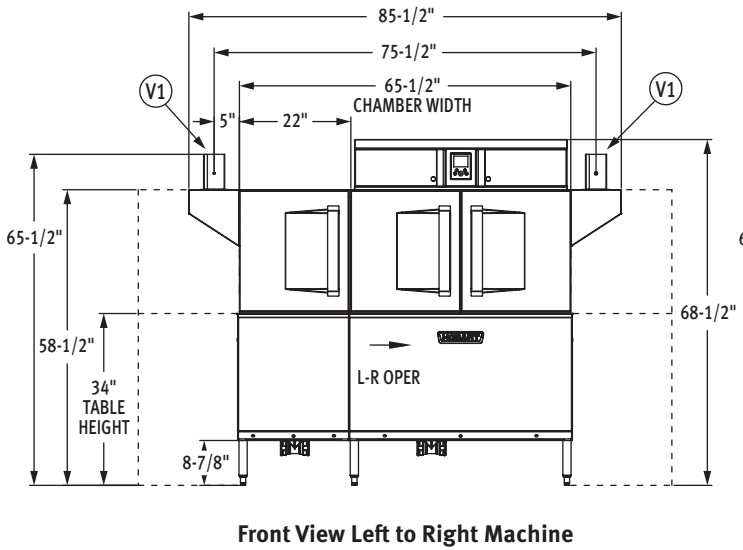
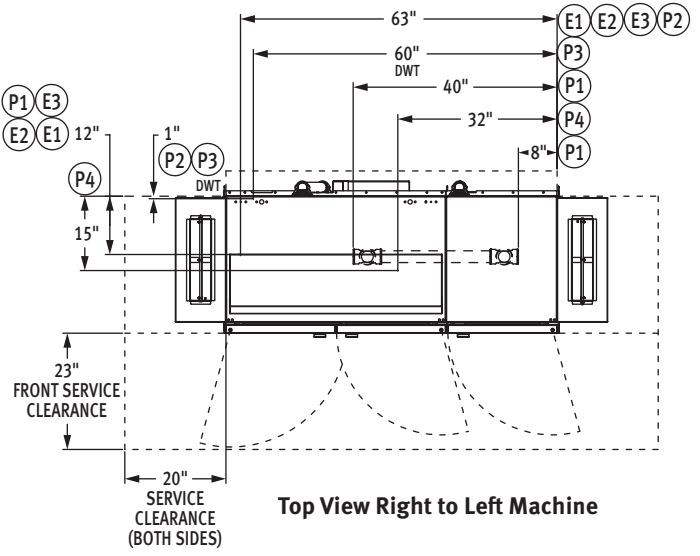
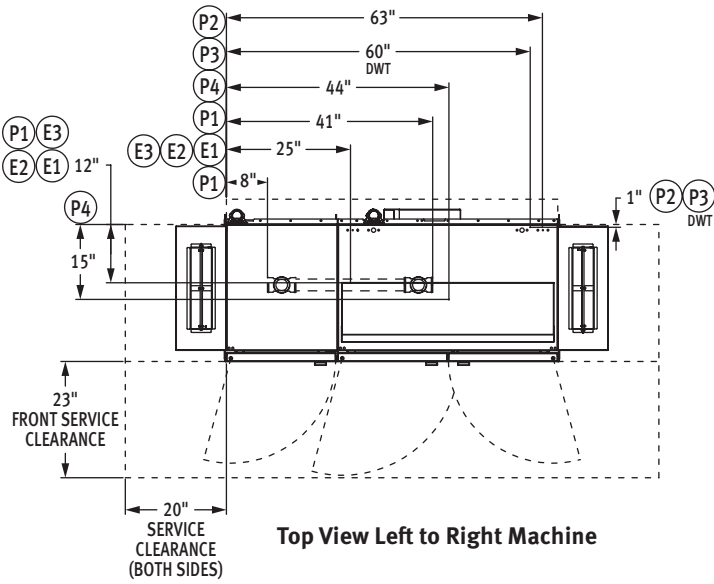

MODEL: CL44-BAS GAS  
L-R OPERATION  
00-563923  
REVA

MODEL: CL44-BAS GAS  
R-L OPERATION  
00-563923  
REVA



# CL66-BAS GAS

## High Temperature Rack Conveyor Dishwashing Machine

### LEGEND

Electrical Connections	
SINGLE POINT CONNECTION	
E1	Electric connection, single point: motors, controls, with 18 kW electric booster heater, 65" AFF.
DUAL POINT CONNECTION WITH BOOSTER	
E2	Electric connection: motors, 62" AFF.
E3	Electric connection: controls, 18kW booster heater, 65" AFF.
Plumbing Connections	
P1	Drain: 2" FPT, 7-3/8" AFF, two possible connections; may be drained to either side of drain housing, plug opposite side.
P2	Common hot water connection: 1/2" FPT, 12" AFF. See plumbing notes for required temperatures.
P3	Optional drain water tempering. Cold water connection: 1/2" FPT, 12" AFF, cold temperature 80°F maximum.
P4	Gas connection – Natural, 1/2" FPT, 11" AFF; 3.5" minimum, 7" maximum W.C. incoming.
P4	Gas connection – L.P., 1/2" FPT, 11" AFF; 8" minimum, 11" maximum W.C. incoming.
Vent Connections	
V1	Optional vent hoods: 4" x 16" vent stack with damper. Load end 200 CFM, unload end 400 CFM.

### SPECIFICATIONS

#### Capacities

Racks per Hour (NSF rated)	202
Wash Tank (U.S. gallons)	23
Power Scraper (U.S. gallons)	23
Conveyor Speed (feet per minute)	5.6

#### Motor Horsepower

Drive	1/6
Wash	2
Power Scraper	2
Final Rinse	2/3

#### Water Consumption

U.S. Gallons per Hour (maximum use at 20 PSI)	90
U.S. Gallons per Rack	0.45
Peak Drain Flow (U.S. gallons per minute)	38

#### Heating

Tank Heat, LP or Natural Gas (BTU per hour)	78,000
Electric Booster (built-in) (kW for 70°F rise)	18
Electric Booster (field conversion) (kW for 40°F rise)	12

#### Venting

Load End (minimum CFM)	200
Unload End (minimum CFM)	400

Shipping Weight (approximate) .855 lbs.

Crated Dimensions . . . . . 76"L x 38"W x 79"H

E1	Single Point Electrical Connection with Internal Booster	
	(E1) Motors, Controls, 18 kW Booster Heater	
Voltage	Rated Amps	Minimum Supply Circuit Ampacity/ Maximum Protective Device
	208/60/3	71.6
240/60/3	62.8	80

E2 E3	Dual Point Electrical Connection with Internal Booster (Field Conversion Only)			
	(E2) Motors		(E3) Controls, 18 kW Booster Heater	
Voltage	Rated Amps	Minimum Supply Circuit Ampacity/ Maximum Protective Device	Rated Amps	Minimum Supply Circuit Ampacity/ Maximum Protective Device
	208/60/3	14.6	20	57.0
240/60/3	12.5	20	50.3	60

**WARNING:** Electrical and grounding connections must comply with the applicable portions of the National Electrical Code and/or other local electrical codes.

**CAUTION:** Certain materials including silver, aluminum, and pewter are attacked by sodium hypochlorite (liquid bleach).

**ATTN:** Plumbing connections must comply with applicable sanitary, safety and plumbing codes.

CL66-BAS Gas Heat Dissipation		
Booster	BTU/HR.	
	Latent	Sensible
Without Booster	26,700	11,400
12kW Booster	34,800	14,900
18kW Booster	40,200	17,200

**NOTE:** 18kW Booster Heater field convertible to 12kW when 140°F incoming water provided. (Conversion instructions located in machine control box. Contact factory for 12kW booster amperage ratings.)

**NOTE:** Additional Voltages and Amperages are available, see document F48913.



# CL66-BAS GAS High Temperature Rack Conveyor Dishwashing Machine

**Plumbing Notes:** Water hammer arrestor (meeting ASSE-1010 standard or equivalent) to be supplied (by others) in common water supply line at service connection.

Recommended water hardness to be 3 grains or less for best results.

Minimum incoming hot water temperatures:

110°F for 18kW internal booster

140°F for 12kW field converted internal booster

180°F without internal booster for high temperature sanitizing

130°F without internal booster for chemical sanitizing

Building flowing water pressure to dish machine is 20 to 65 PSI at the machine.

For convenience when cleaning, water tap should be installed near machine with heavy duty hose and squeeze valve.

For chemical sanitizing applications, feeder must be certified to NSF Standard 29.

For natural gas, pressure to the burner (customer connection) should be 3.5" minimum, 7" maximum W.C.

For LP gas, pressure to the burner (customer connection) should be 8" minimum, 11" maximum W.C.

If gas pressure is higher than 7" (natural) or 11" (LP) W.C., a pressure regulating valve must be installed (by others) in the gas line to the dishwasher.

Gas heat (natural or LP) BTU/Hr. input – 78,000.

Gas exhaust venting must be installed according to local code. Electrical interlock connection provided for customers airflow switch to prevent heat being applied if the exhaust fans are not operating. Do not connect flue to power vent. See installation manual for gas venting.

**Miscellaneous Notes:** All dimensions taken from floor line may be increased approximately 3/4" or decreased 1/2".

**Electrical Note:** Dishmachine not provided with internal GFCI protection.

## VENT HOOD OPTIONS (Adjustable, vent stack can be adjusted 1" to either side)

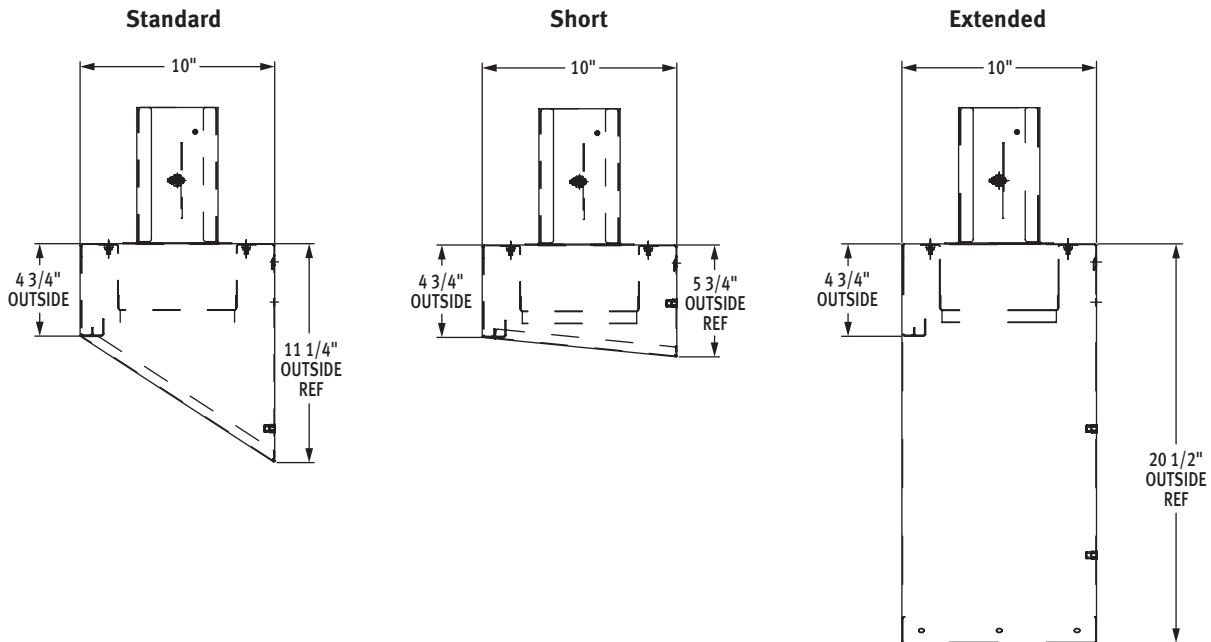

## TABLE CONNECTION DETAILS

**Tabling Connection: 44" inside tank  
(at table connection)**

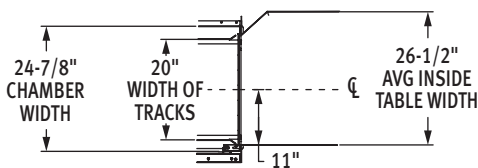

**Suggested Track and Table Layout**

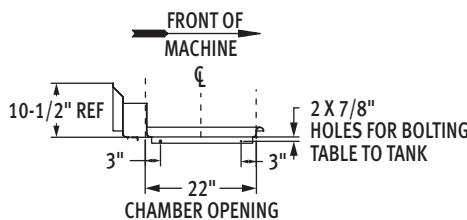

**View Showing Hole Locations in  
Turned Down Portion of Table**



**Sectional View Showing  
Table Connections**

As continued product improvement is a policy of Hobart, specifications are subject to change without notice.